

C | S E R I E S
W I D E S C R E E N



C-Series Widescreen Multifunction Display

Installation instructions

C90W, C120W and C140W models

Raymarine[®]

Trademarks and registered trademarks

Autohelm, HSB, RayTech Navigator, Sail Pilot, SeaTalk and Sportpilot are UK registered trademarks of Raymarine UK Limited. Pathfinder and Raymarine are UK registered trademarks of Raymarine Holdings Limited. 45STV, 60STV, AST, Autoadapt, Auto GST, AutoSeastate, AutoTrim, Bidata, G Series, HDFI, LifeTag, Marine Intelligence, Maxiview, On Board, Raychart, Raynav, Raypilot, RayTalk, Raystar, ST40, ST60+, Seaclutter, Smart Route, Tridata, UniControl and Waypoint Navigation are trademarks of Raymarine UK Limited.

All other product names are trademarks or registered trademarks of their respective owners.

Copyright ©2008 Raymarine UK Ltd. All rights reserved.

ENGLISH

Document number: 87101-1

Date: November 2008

Contents

Chapter 1 Important Information.....	7	3.3 Power connection	23
TFT LCD Displays	8	3.4 SeaTalk ^{hs} network	26
Water ingress	8	3.5 NMEA 0183 connection	32
Disclaimers	8	3.6 SeaTalk connection	33
CompactFlash cards	9	3.7 Alarm connection	34
EMC installation guidelines	9	3.8 GPS connection	35
Suppression ferrites	10	3.9 AIS connection.....	36
Connections to other equipment	10	3.10 Fastheading connection.....	36
Declaration of conformity.....	10	3.11 SeaTalk ^{ng} connections	37
Product disposal	10	3.12 NMEA 2000 connection	38
Warranty registration.....	10	3.13 Video connection.....	39
IMO and SOLAS.....	11	Chapter 4 Location and mounting	41
Technical accuracy	11	4.1 Selecting a location	42
Chapter 2 Planning the installation	13	4.2 Flush mounting	45
2.1 Handbook information	14	4.3 Bracket (trunnion) mounting.....	46
2.2 Installation checklist	14	4.4 Front bezel	48
2.3 C-Series systems	15	Chapter 5 System checks	51
2.4 Pack contents	17	5.1 Initial power on test	52
2.5 Tools	19	5.2 GPS check	53
Chapter 3 Cables and connections.....	21	5.3 Radar check	54
3.1 General cabling guidance	22	5.4 Sonar check	56
3.2 Connections overview	23	5.5 Language selection	57

Chapter 6 Troubleshooting	59	Appendix C NMEA 2000 sentences	87
6.1 Troubleshooting	60		
6.2 Power up troubleshooting	60		
6.3 Radar troubleshooting	61		
6.4 GPS troubleshooting	62		
6.5 Sonar troubleshooting	63		
6.6 System data troubleshooting.....	64		
6.7 SeaTalk ^{hs} LED indications.....	65		
6.8 Miscellaneous troubleshooting	66		
Chapter 7 Technical support	69		
7.1 Raymarine technical support.....	70		
7.2 Sirius support.....	70		
7.3 Navionics support	71		
Chapter 8 Technical specification	73		
8.1 Technical specification	74		
Chapter 9 Options and accessories	77		
9.1 SeaTalk accessories.....	78		
9.2 SeaTalk ^{ng} accessories	78		
9.3 SeaTalk ^{hs} accessories	79		
9.4 Spares and accessories	81		
Appendix A Connectors and pinouts	83		
Appendix B NMEA 0183 sentences	85		

Chapter 1: Important Information



Warning: Product installation

This equipment must be installed in accordance with the Raymarine instructions provided. Failure to do so could result in poor product performance, personal injury, and/or damage to the vessel.



Warning: Potential ignition source

This product is NOT approved for use in hazardous/flammable atmospheres. Do NOT install in a hazardous/flammable atmosphere (such as in an engine room or near fuel tanks).



Warning: High voltages

This product contains high voltages. Do NOT remove any covers or otherwise attempt to access internal components, unless specifically instructed in this document.



Warning: Grounding

This display is not intended for use on “positive” ground boats. The power input cable drain wires must be connected directly to the boats ground.



Warning: Switch off power supply

Ensure the boat's power supply is switched OFF before starting to install this product. Do NOT connect or disconnect equipment with the power switched on, unless instructed in this document.



Warning: Radar scanner safety

Before rotating the radar scanner, ensure all personnel are clear.



Warning: Radar transmission safety

The radar scanner transmits electromagnetic energy. Ensure all personnel are clear of the scanner when the radar is transmitting.



Warning: Sonar operation

- NEVER operate the sounder with the boat out of the water.
- NEVER touch the transducer face when the sounder is powered on.
- SWITCH OFF the sounder if divers are likely to be within 25 ft (5 m) of the transducer.

Caution: Power supply protection

When installing this product ensure the power source is adequately protected by means of a suitably-rated fuse or automatic circuit breaker.

Caution: Care of chart cards

To avoid irreparable damage to and/or loss of data from chart cards:

- Ensure that chart cards are fitted the correct way around. DO NOT try to force a card into position.
- DO NOT save data (waypoints, routes, and so on) to a Navionics chart card, as the charts may be overwritten.
- DO NOT use a metallic instrument such as a screwdriver or pliers to remove a chart card.
- DO NOT remove a chart card while information is being written to or read from it.

Caution: Ensure chart card door is securely closed

To prevent water ingress and consequent damage to the display, ensure that the chart card door is firmly closed. This can be confirmed by an audible click.

Caution: Use the sun covers

To protect your product against the damaging effects of ultra violet light, always fit the sun covers when the product is not in use.

Caution: Cleaning

When cleaning this product do NOT use acid, ammonia-based or abrasive products, and do NOT use high pressure washing (jet wash) equipment.

TFT LCD Displays

The colors of the display may seem to vary when viewed against a colored background or in colored light. This is a perfectly normal effect that can be seen with all color Liquid Crystal Displays (LCDs).

In common with all Thin Film Transistor (TFT) LCD units, the screen may exhibit a few (less than 7) wrongly illuminated pixels. These may appear as black pixels in a light area of the screen or as colored pixels in black areas.

Water ingress

As it exceeds the water proof rating capacity outlined by standards IPX6, subjecting any Raymarine equipment to commercial high pressure washing equipment may cause water intrusion and subsequent equipment failure. Raymarine will not warrant equipment subjected to high pressure washing.

Disclaimers

This product (including the electronic charts) is intended to be used only as an aid to navigation. It is designed to facilitate use of official government charts, not replace them. Only official government charts and notices to mariners contain all the current information needed for safe navigation, and the captain is responsible for their

prudent use. It is the user's responsibility to use official government charts, notices to mariners, caution and proper navigational skill when operating this or any other Raymarine product. This product supports electronic charts provided by third party data suppliers which may be embedded or stored on memory card. Use of such charts is subject to the supplier's End-User Licence Agreement included in the documentation for this product or supplied with the memory card (as applicable).

Raymarine does not warrant that this product is error-free or that it is compatible with products manufactured by any person or entity other than Raymarine.

This product uses digital chart data, and electronic information from the Global Positioning System (GPS) which may contain errors. Raymarine does not warrant the accuracy of such information and you are advised that errors in such information may cause the product to malfunction. Raymarine is not responsible for damages or injuries caused by your use or inability to use the product, by the interaction of the product with products manufactured by others, or by errors in chart data or information utilized by the product and supplied by third parties.

CompactFlash cards

Navionics chart cards

The Display is pre-loaded with Navionics chart data. If you wish to use different chart data, you can insert Navionics chart cards into the CompactFlash card slot on the unit.

Use branded chart cards

When archiving data, Raymarine recommends the use of SanDisk CF memory cards. Other brands of CF memory card may not work in your unit.

EMC installation guidelines

Raymarine equipment and accessories conform to the appropriate Electromagnetic Compatibility (EMC) regulations, to minimize electromagnetic interference between equipment and minimize the effect such interference could have on the performance of your system

Correct installation is required to ensure that EMC performance is not compromised.

For **optimum** EMC performance we recommended that wherever possible:

- Raymarine equipment and cables connected to it are:
 - At least 1 m (3 ft) from any equipment transmitting or cables carrying radio signals e.g. VHF radios, cables and antennas. In the case of SSB radios, the distance should be increased to 7 ft (2 m).
 - More than 2 m (7 ft) from the path of a radar beam. A radar beam can normally be assumed to spread 20 degrees above and below the radiating element.
- The product is supplied from a separate battery from that used for engine start. This is important to prevent erratic behavior and data loss which can occur if the engine start does not have a separate battery.
- Raymarine specified cables are used.
- Cables are not cut or extended, unless doing so is detailed in the installation manual.

Note: Where constraints on the installation prevent any of the above recommendations, always ensure the maximum possible separation between different items of electrical equipment, to provide the best conditions for EMC performance throughout the installation

Suppression ferrites

Do not remove ferrite

Raymarine cables may be fitted with suppression ferrites. These are important for correct EMC performance. If a ferrite has to be removed for any purpose (e.g. installation or maintenance), it must be replaced in the original position before the product is used.

Use only ferrites of the correct type, supplied by Raymarine authorized dealers.

Connections to other equipment

Requirement for ferrites on non-Raymarine cables

If your Raymarine equipment is to be connected to other equipment using a cable not supplied by Raymarine, a suppression ferrite **MUST** always be attached to the cable near the Raymarine unit.

Declaration of conformity

Raymarine Ltd. declares that the C-Series Multifunction Displays are in compliance with the essential requirements of EMC directive 2004/108/EC.

The original Declaration of Conformity certificate may be viewed on the relevant product page at www.raymarine.com

Product disposal

Dispose this product in accordance with the WEEE Directive.



The Waste Electrical and Electronic Equipment (WEEE) Directive requires the recycling of waste electrical and electronic equipment. Whilst the WEEE Directive does not apply to some Raymarine products, we support its policy and ask you to be aware of how to dispose of this product.

Warranty registration

To register your C-Series multifunction display ownership, please take a few minutes to fill out the warranty registration card found in the box, or visit www.raymarine.com and register on-line.

It is important that you register your product to receive full warranty benefits. Your unit package includes a bar code label indicating the serial number of the unit. You should stick this label to the warranty registration card.

IMO and SOLAS

The equipment described within this document is intended for use on leisure marine boats and workboats not covered by International Maritime Organization (IMO) and Safety of Life at Sea (SOLAS) Carriage Regulations.

Technical accuracy

To the best of our knowledge, the information in this document was correct at the time it was produced. However, Raymarine cannot accept liability for any inaccuracies or omissions it may contain. In addition, our policy of continuous product improvement may change specifications without notice. As a result, Raymarine cannot accept liability for any differences between the product and this document.

Chapter 2: Planning the installation

Chapter contents

- [2.1 Handbook information on page 14](#)
- [2.2 Installation checklist on page 14](#)
- [2.3 C-Series systems on page 15](#)
- [2.4 Pack contents on page 17](#)
- [2.5 Tools on page 19](#)

2.1 Handbook information

This handbook contains important information on installing the C-Series Widescreen range of multifunction displays.

The handbook is for use with the following models:

- C90W Widescreen Multifunction Display
- C120W Widescreen Multifunction Display
- C140W Widescreen Multifunction Display

C-Series handbooks

The C-Series Widescreen Multifunction Display has the following handbooks available.

All documents are available to download as PDFs from www.raymarine.com

C-Series handbooks

Description	Part number
Installation and commissioning instructions	87101
Operating instructions (quick reference)	86135
User reference handbook	81312

Additional handbooks

Description	Part number
SeaTalk ^{ng} reference manual	81300

2.2 Installation checklist

Installation includes the following activities:

Installation Task	
1	Plan your system
2	Obtain all required equipment and tools
3	Site all equipment
4	Route all cables.
5	Drill cable and mounting holes.
6	Make all connections into equipment.
7	Secure all equipment in place.
8	Power on test the system.

2.3 C-Series systems

The C-Series display can be used in a number of system types. Some examples are outlined here.

Example system

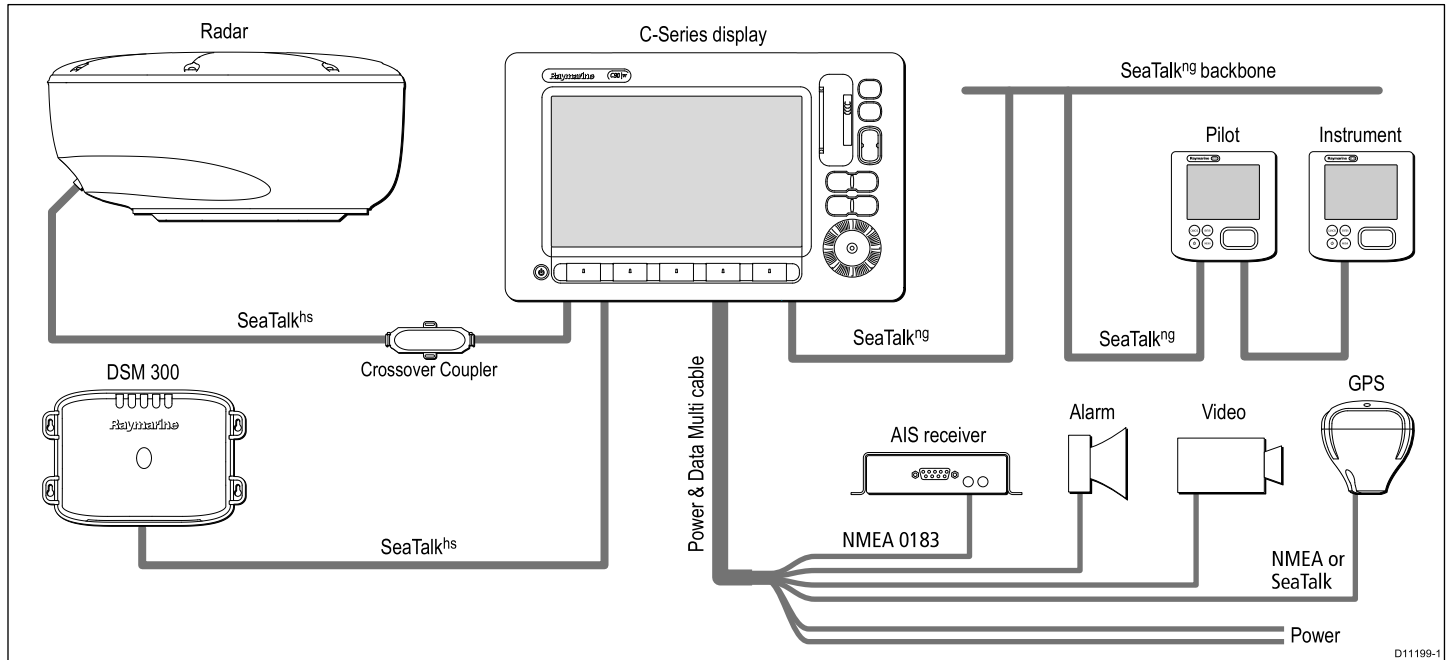

C-Series protocols

Your C-Series Widescreen Multifunction Display can connect to various instruments and displays to share information and so improve the functionality of the system. These connections may be made using a number of different protocols. Fast and accurate data collection and transfer is achieved by using a combination of the following data protocols:

- SeaTalk^{hs}
- SeaTalk^{ng}
- NMEA 2000
- SeaTalk
- NMEA 0183

Note: You may find that your system does not use all of the connection types or instrumentation described in this section.

SeaTalk^{hs}

SeaTalk^{hs} is an ethernet based marine network. This high speed protocol allows compatible equipment to communicate rapidly and share large amounts of data.

Information shared using the SeaTalk^{hs} network includes:

- Shared cartography (between compatible displays).
- Digital radar data.
- Sonar data.

Seatalk^{ng}

SeaTalk^{ng} (New Generation) is an enhanced protocol for connection of compatible marine instruments and equipment. It replaces the older SeaTalk and SeaTalk² protocols.

SeaTalk^{ng} utilizes a single backbone cable to which compatible instruments connect using a spur. Data and power are carried within the backbone. Devices that have a low draw can be powered from the network, although high current equipment will need to have a separate power connection.

SeaTalk^{ng} is a proprietary extension to NMEA 2000 and the proven CAN bus technology. Compatible NMEA 2000 and SeaTalk / SeaTalk² devices can also be connected using the appropriate interfaces or adaptor cables as required.

NMEA 2000

NMEA 2000 offers significant improvements over NMEA 0183, most notably in speed and connectivity. Up to 50 units can simultaneously transmit and receive on a single physical bus at any one time, with each node being physically addressable. The standard was specifically intended to allow for a whole network of marine electronics from any manufacturer to communicate on a common bus via standardized message types and formats.

SeaTalk

SeaTalk is a protocol which enables compatible instruments to connect to each other and share data.

The SeaTalk cable system is used to connect compatible instruments and equipment. The cable carries power and data and enables connection without the need for a central processor.

Additional instruments and functions can be added to a SeaTalk system, simply by plugging them into the network. SeaTalk equipment can also communicate with other non-SeaTalk equipment via the NMEA 0183 standard, provided a suitable interface is used.

NMEA 0183

The NMEA 0183 Data Interface Standard was developed by the National Marine Electronics Association of America. It is an international standard to enable equipment from many different manufacturers to be connected together and share information.

The NMEA 0183 standard carries similar information to SeaTalk. However it has the important difference that one cable will only carry information in one direction. For this reason NMEA 0183 is generally used to connect a data receiver and a transmitter together, e.g. a compass sensor transmitting heading to a radar display. This information is passed in 'sentences', each of which has a three letter sentence identifier. It is therefore important when checking compatibility between items that the same sentence identifiers are used some examples of which are:

- VTG - carries Course and Speed Over Ground data.
- GLL - carries latitude and longitude.
- DBT - carries water depth.
- MWV - carries relative wind angle and wind speed data.

NMEA baud rates

The NMEA 0183 standard operates at a number of different speeds, depending upon the particular requirement or equipment capabilities. Typical examples are:

- 4800 baud rate. Used for general purpose communications, including FastHeading data.
- 9600 baud rate. Used for Navtex.
- 38400 baud rate. Used for AIS and other high speed applications.

2.4 Pack contents

Unpack the display unit carefully to prevent damage. Save the carton and packing in case the unit has to be returned for service.

All models contain the following items:

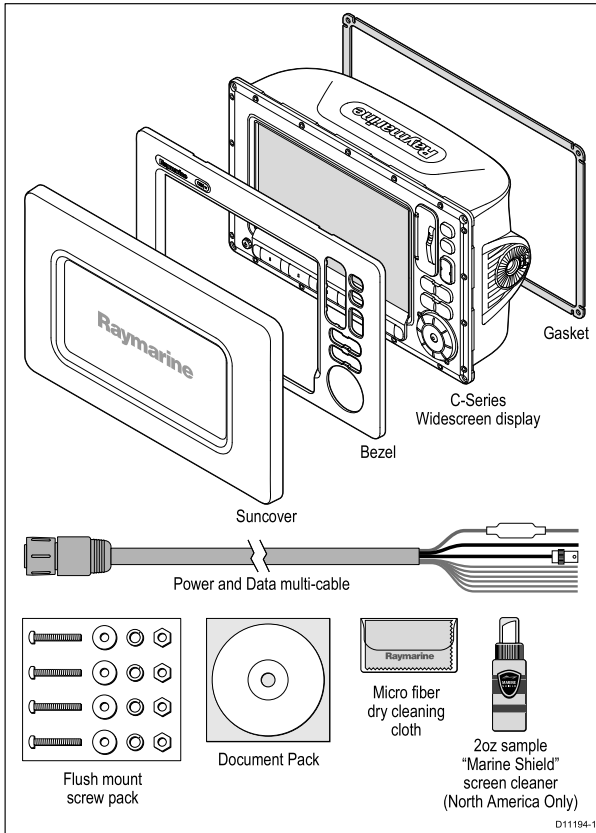

Description
Bezel
Gasket
Suncover
1.5 m (4.9 ft) Power and data cable
Screw pack
Document pack, includes: <ul style="list-style-type: none"> • Multilingual CD • Installation instructions • Cutting template
Micro fiber cleaning cloth
Marine shield screen clean sample (North America only)

Description
C-Series Widescreen Multifunction Display

2.5 Tools

Tools required for installation

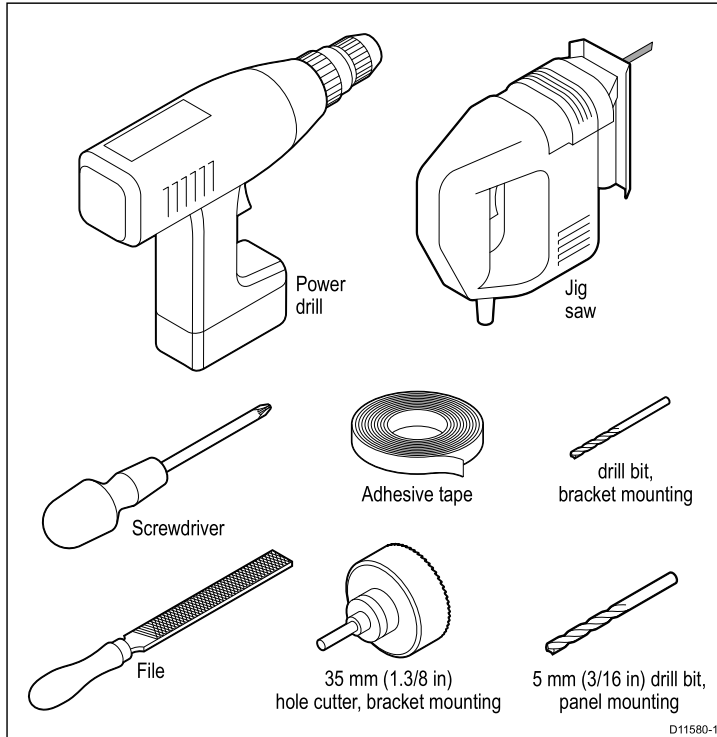

Chapter 3: Cables and connections

Chapter contents

- [3.1 General cabling guidance on page 22](#)
- [3.2 Connections overview on page 23](#)
- [3.3 Power connection on page 23](#)
- [3.4 SeaTalk^{hs} network on page 26](#)
- [3.5 NMEA 0183 connection on page 32](#)
- [3.6 SeaTalk connection on page 33](#)
- [3.7 Alarm connection on page 34](#)
- [3.8 GPS connection on page 35](#)
- [3.9 AIS connection on page 36](#)
- [3.10 Fastheading connection on page 36](#)
- [3.11 SeaTalk^{ng} connections on page 37](#)
- [3.12 NMEA 2000 connection on page 38](#)
- [3.13 Video connection on page 39](#)

3.1 General cabling guidance

Cable types and length

It is important to use cables of the appropriate type and length

- Unless otherwise stated use only standard cables of the correct type, supplied by Raymarine.
- Ensure that any non-Raymarine cables are of the correct quality and gauge. For example, longer power cable runs may require larger wire gauges to minimize voltage drop along the run.

Routing cables

Cables must be routed correctly, to maximize performance and prolong cable life.

- Do NOT bend cables excessively. Wherever possible, ensure a minimum bend radius of 100 mm.

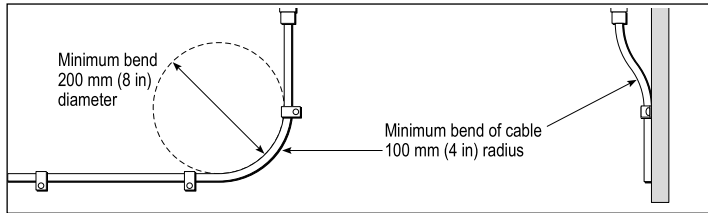

- Protect all cables from physical damage and exposure to heat. Use trunking or conduit where possible. Do NOT run cables through bilges or doorways, or close to moving or hot objects.
- Secure cables in place using tie-wraps or lacing twine. Coil any extra cable and tie it out of the way.
- Where a cable passes through an exposed bulkhead or deckhead, use a suitable watertight feed-through.

- Do NOT run cables near to engines or fluorescent lights.

Always route data cables as far away as possible from:

- other equipment and cables,
- high current carrying ac and dc power lines,
- antennae.

Strain relief

Ensure adequate strain relief is provided. Protect connectors from strain and ensure they will not pull out under extreme sea conditions.

Circuit isolation

Appropriate circuit isolation is required for installations using both AC and DC current:

- Always use isolating transformers or a separate power-inverter to run PC's, processors, displays and other sensitive electronic instruments or devices.
- Always use an isolating transformer with Weather FAX audio cables.
- Always use an RS232/NMEA converter with optical isolation on the signal lines.
- Always make sure that PC's or other sensitive electronic devices have a dedicated power circuit.

Cable shielding

Ensure that all data cables are properly shielded that the cable shielding is intact (e.g. hasn't been scraped off by being squeezed through a tight area).

3.2 Connections overview

Cable connectors are on the rear of the display

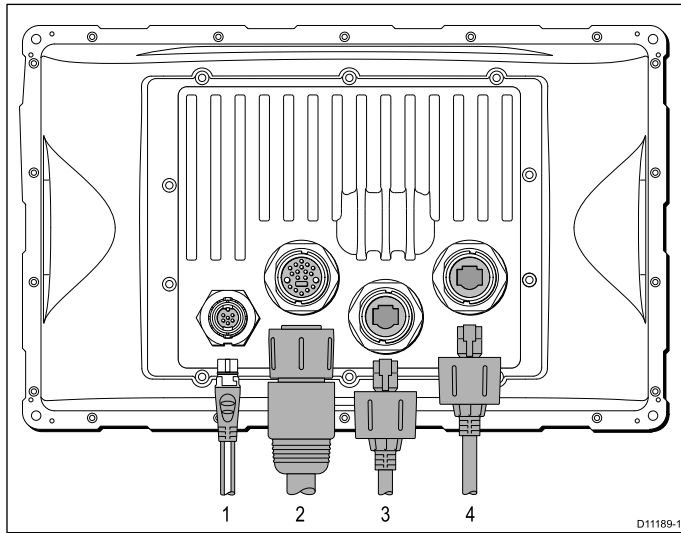

1. SeaTalk^{ng}
2. Power and data
3. SeaTalk^{hs}
4. SeaTalk^{hs}

3.3 Power connection

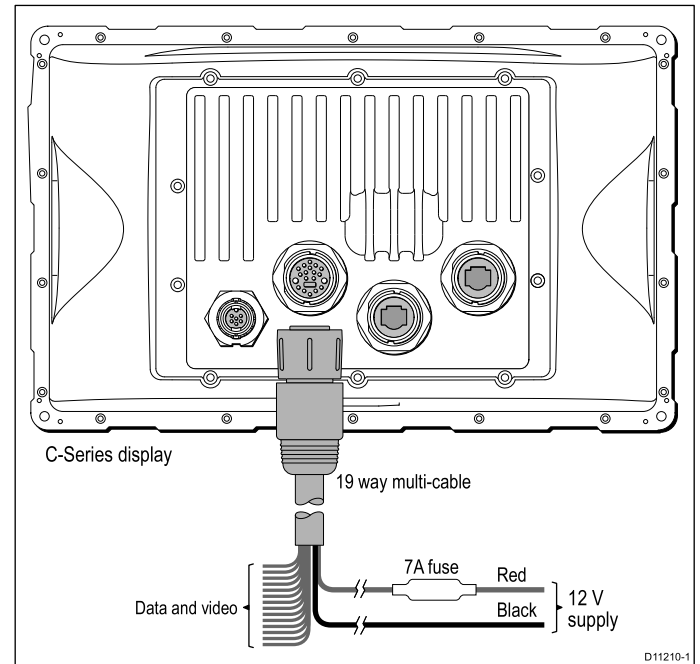

Power distribution

Raymarine recommend that all power connections are made via a distribution panel.

- All equipment must be powered from a breaker or switch, with appropriate circuit protection.
- All equipment should where possible be wired to individual breakers.



Warning: Grounding

This display is not intended for use on “positive” ground boats. The power input cable drain wires must be connected directly to the boats ground.

Grounding

The following requirements apply when grounding Raymarine equipment:

- Use a dedicated earthing plate (e.g. dynaplate) in contact with the water.
- Ground cables may be routed to a common point (e.g. within the switch panel. With a single (appropriately rated) copper braid connecting to the earthing plate.
- Use flat tinned copper braid, 30 A rating (1/4 inch) or greater. Equivalent stranded wire diameter 4 mm or greater.
- Keep the length of the earth braid as short as possible.

Power cable

The C-Series display is supplied with a combined power and data multi cable, this can be extended if required.

Power cable supplied

Cable	Part number	Notes
1.5 m (4.9 ft) Power and data cable	R62131	Supplied with C-Series unit

Cable extension

The following restrictions apply to any extension to the power cable:

- Cable must be of a suitable gauge for the circuit load.
- Each unit should have its own dedicated power cable wired back to the distribution panel.

Total length (max)	Supply voltage	Cable gauge (AWG)
0–5 m (0–16.4 ft)	12 V	18
	24 V	20
5–10 m (16.4–32.8 ft)	12 V	14
	24 V	18
10–15 m (32.8–49.2 ft)	12 V	12
	24 V	16
15–20 m (49.2–65.5 ft)	12 V	12
	24 V	14

Note: These distances are for a 2 wire power cable run from the battery to the display (approximately the distance from the battery to the display). To calculate the round trip length, double the figure stated here.

Breakers, fuses and circuit protection

The C-Series Widescreen power cable includes an in-line fuse. You can use an additional thermal breaker or fuse at the distribution panel if you wish.

Display	Fuse
<ul style="list-style-type: none"> • C90W • C120W • C140W 	7 A in-line fuse fitted within power cable.

Sharing a breaker

Where more than 1 piece of equipment shares a breaker you must provide protection for the individual circuits. E.g. an in-line fuse for each power circuit

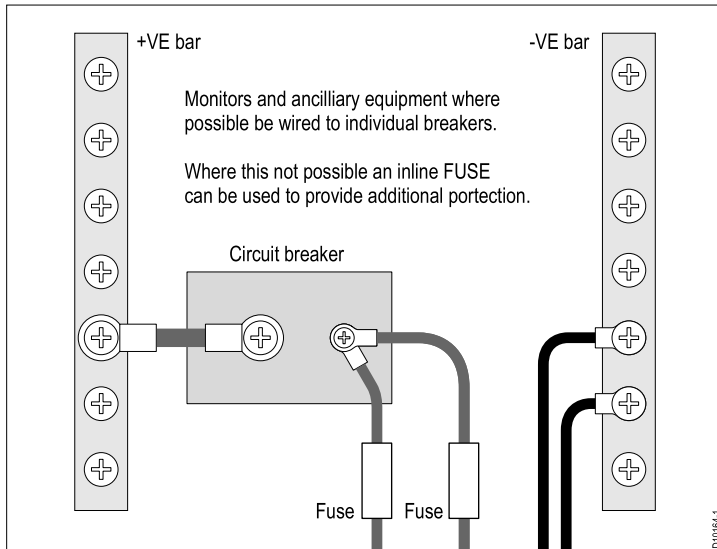

3.4 SeaTalk^{hs} network

The SeaTalk^{hs} network allows you to network compatible displays and other digital devices.

The C-Series Widescreen Display can use SeaTalk^{hs} to connect to:

- Another C-Series Widescreen Display.
- A digital radar scanner.
- A DSM300 or DSM30 sonar module.
- A SeaTalk^{hs} switch.

Typical SeaTalk^{hs} network

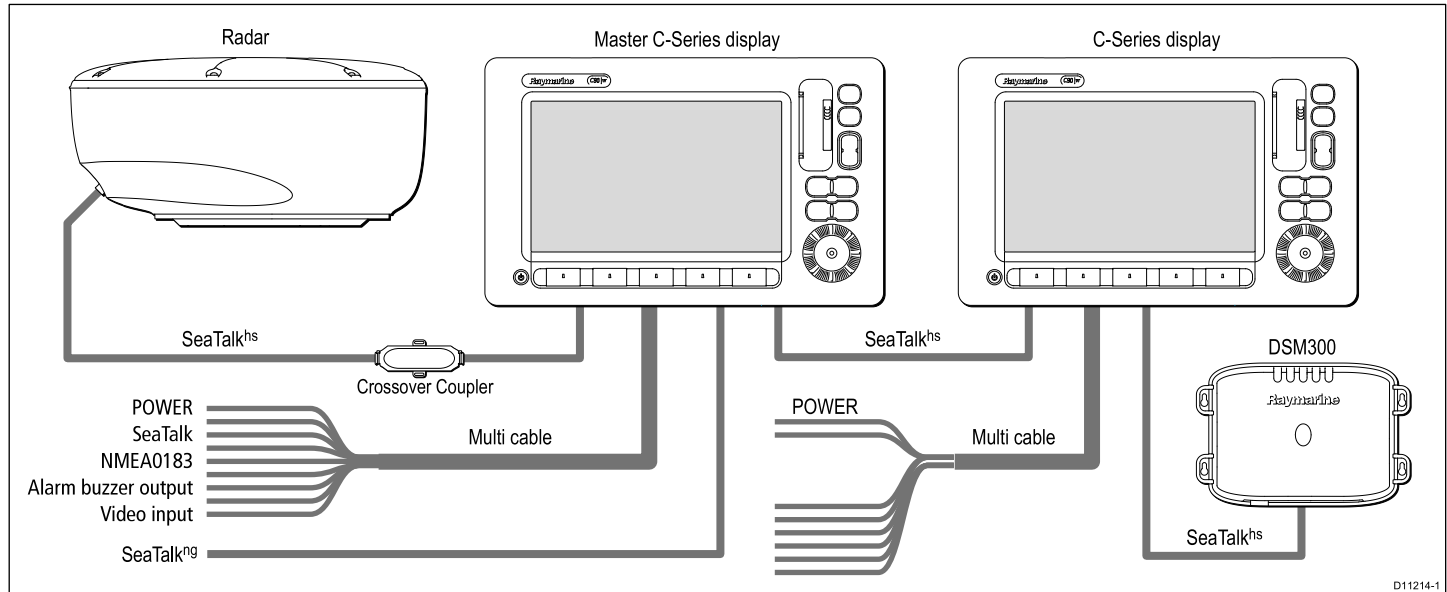

SeaTalk^{hs} display to display cables

You can connect up to 2 C-Series Widescreen displays together using SeaTalk^{hs}. Connect the displays directly or use a SeaTalk^{hs} switch.

SeaTalk^{hs} network cables

Connect from the SeaTalk^{hs} switch into the rear of the display.

Cable	Part number	Notes
1.5 m (4.9 ft) SeaTalk ^{hs} network cable	E55049	
5 m (16.4 ft) SeaTalk ^{hs} network cable	E55050	
10 m (32.8 ft) SeaTalk ^{hs} network cable	E55051	
20 m () SeaTalk ^{hs} network cable	E55052	

Fully waterproof SeaTalk^{hs} network cables

Connect directly from display to display.

Cable	Part number	Notes
1.5 m (4.9 ft) Dual end SeaTalk ^{hs} network cable.	A62245	Cable has waterproof connectors at both ends.
15 m (49.2 ft) Dual end SeaTalk ^{hs} network cable	A62246	Cable has waterproof connectors at both ends.

Radar connection

C-Series Widescreen displays are compatible with Raymarine digital radar scanners. The scanner is connected using a SeaTalk^{hs} cable.

The digital radar can be connected either directly to the C-Series display or via a SeaTalk^{hs} switch.

Radar connected directly to the C-Series unit

Note: The connector on the free end of the radar cable does not have a locking / weather tight mechanism. The use of a crossover coupler is important to create a weather proof connection.

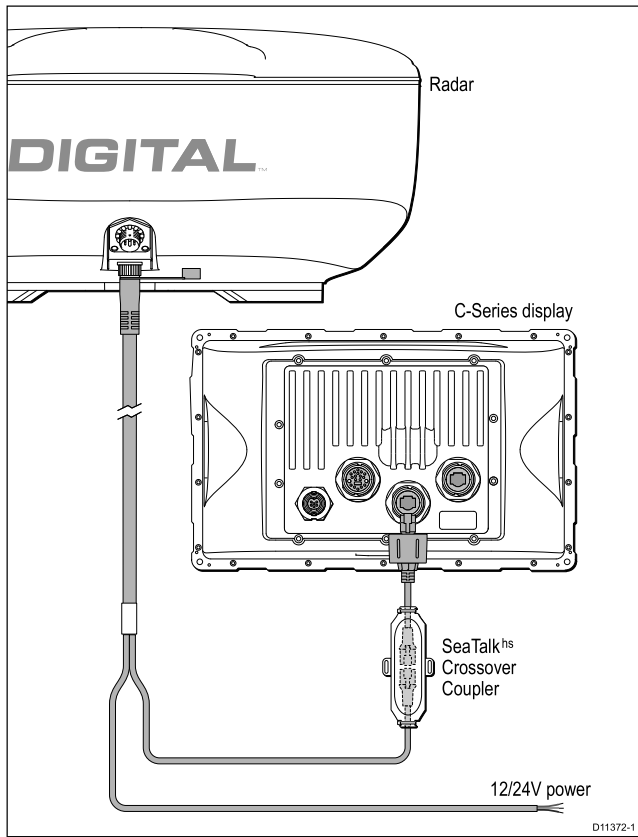

Radar connected using SeaTalk^{hs} switch

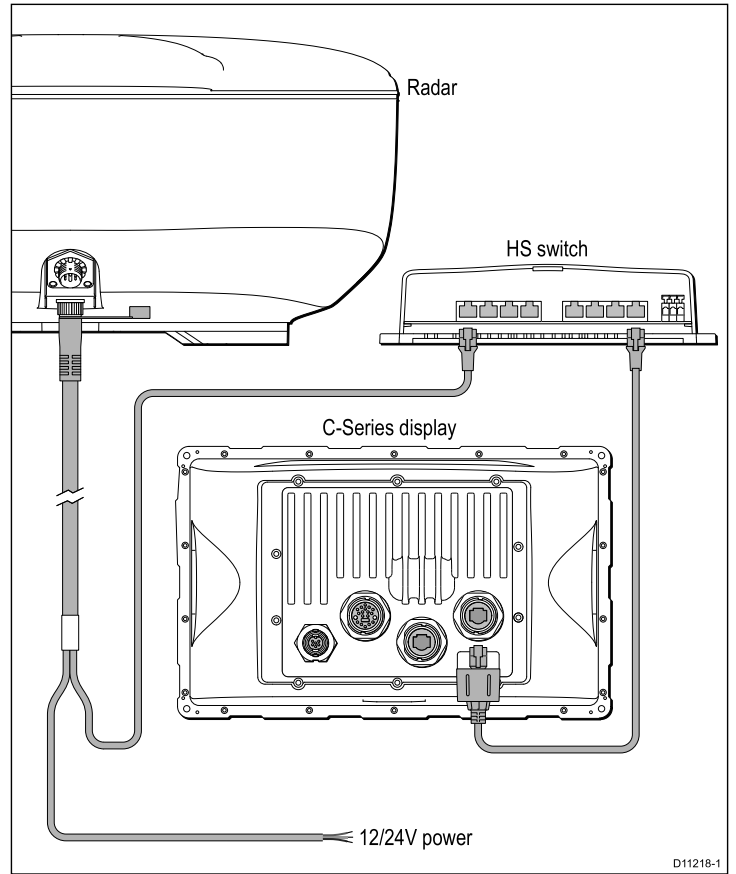

Digital radar cables

You will need at least 2 cables to connect the digital radar scanner. One cable connects the scanner to a SeaTalk^{hs} switch (or cross over coupler). The second cable then connects into the display.

Note: The maximum cable length including all extensions is 25 m (82 ft).

Radar scanner to SeaTalk^{hs} switch (or cross over coupler)

Digital scanner cables

Connect the Radar scanner to the SeaTalk^{hs} switch (or cross over coupler) and power supply. These cables contain both power and data wires.

Cable	Part number	Notes
5 m (16.4 ft) Digital cable	A55076	
10 m (32.8 ft) Digital cable	A55077	Your radar scanner may include the 10 m cable (depending upon the model purchased)
15 m (49.2 ft) Digital cable	A55078	
25 m (82.0 ft) Digital cable	A55079	

Extension cables

Use of one of these cables to extend the radar connection to the SeaTalk^{hs} switch (or cross over coupler) and power supply. These cables contain both power and data wires.

Cable	Part number	Notes
2.5 m (8.2 ft) extension cable	A92141	
5 m (16.4 ft) extension cable	A55080	
10 m (32.8 ft) extension cable	A55081	

SeaTalk^{hs} switch (or cross over coupler) to display unit

SeaTalk^{hs} network cables

Connect from the SeaTalk^{hs} switch or the cross over coupler into the rear of the display.

Cable	Part number	Notes
1.5 m (4.9 ft) SeaTalk ^{hs} network cable	E55049	
5 m (16.4 ft) SeaTalk ^{hs} network cable	E55050	
10 m (32.8 ft) SeaTalk ^{hs} network cable	E55051	
20 m (65.6 ft) SeaTalk ^{hs} network cable	E55052	

SeaTalk^{hs} hardware

To connect the digital radar to the C-Series display you will need to include one of the following

Cable	Part number	Notes
SeaTalk ^{hs} switch	E55058	8 way hub for network connection of multiple SeaTalk ^{hs} devices.
SeaTalk ^{hs} coupler	E55060	Coupler for connection of a single SeaTalk ^{hs} device.

Sonar connection

The sonar connection is required for fishfinder applications. The C-Series display is connected to a sonar module (DSM) using a SeaTalk^{hs} cable. You will also require a compatible transducer connected to the DSM unit.

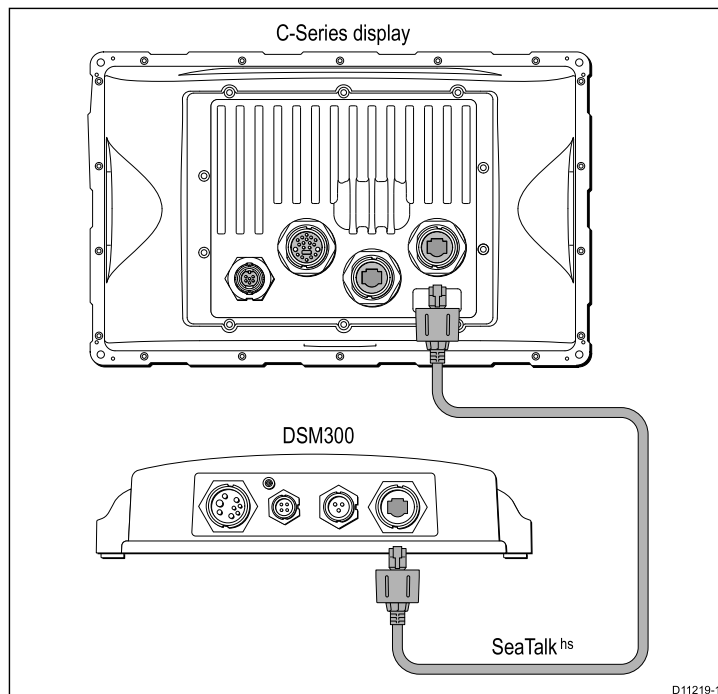

The C-Series display can be used with the following DSM units

- DSM300
- DSM30

The C-Series can support 1 DSM module

Typical DSM system

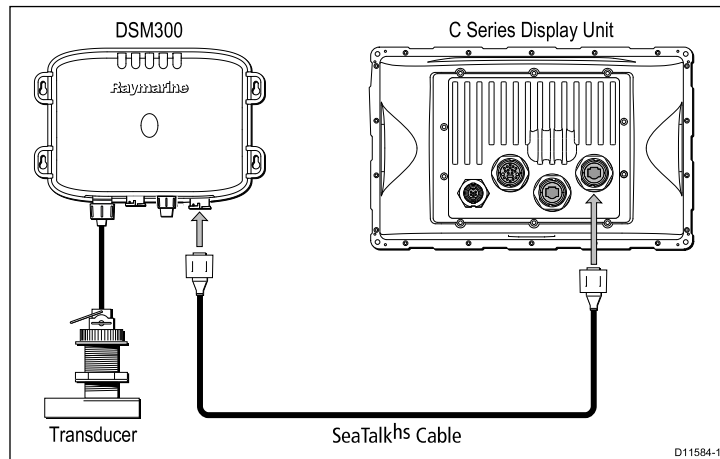

Sonar cable

Connect the DSM unit directly to your display, or connect via the SeaTalk^{hs} switch.

SeaTalk^{hs} network cables

Connect from the SeaTalk^{hs} switch into the rear of the display.

Cable	Part number	Notes
1.5 m (4.9 ft) SeaTalk ^{hs} network cable	E55049	
5 m (16.4 ft) SeaTalk ^{hs} network cable	E55050	

Cable	Part number	Notes
10 m (32.8 ft) SeaTalk ^{hs} network cable	E55051	
20 m (65.6 ft) SeaTalk ^{hs} network cable	E55052	

Fully waterproof SeaTalk^{hs} network cables

Connect directly from DSM to the rear of the display.

Cable	Part number	Notes
1.5 m (4.9 ft) SeaTalk ^{hs} network cable.	A62245	Cable has waterproof connectors at both ends.
10 m (32.8 ft) SeaTalk ^{hs} network cable	A62246	Cable has waterproof connectors at both ends.

3.5 NMEA 0183 connection

Connections to NMEA 0183 devices are made using the supplied Power and data cable.

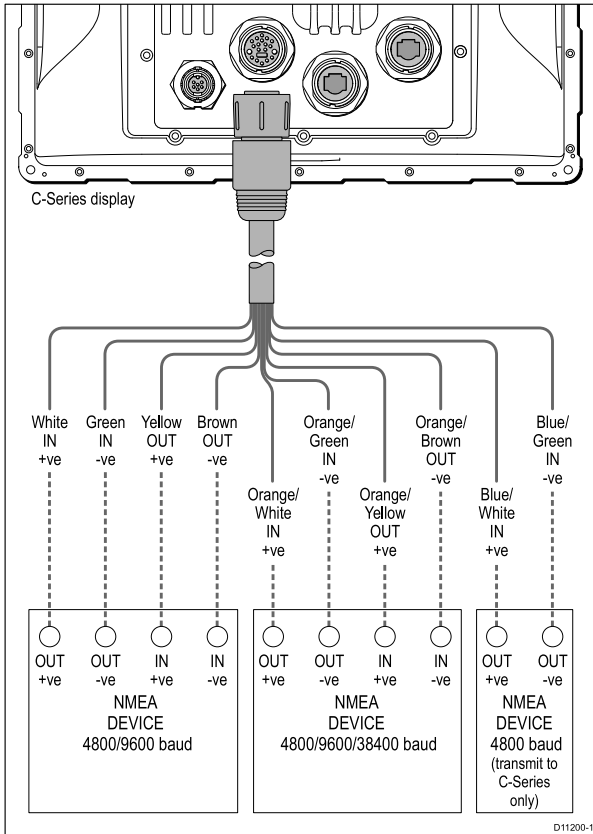

The C-Series has 3 NMEA ports available:

- **Port 1:** Input and output, 4800 / 9600 baud rate.
- **Port 2:** Input and output, up to 38400 baud rate.
- **Port 3:** Input only, 4800 baud rate.

NMEA 0183 cable

You can extend the NMEA 0183 wires within the supplied power and data cable.

Data cable extension

The following restrictions apply to any extension to the NMEA 0183 data wires.

Total length (max)	Cable
Up to 5 m	High quality data cable: <ul style="list-style-type: none"> • 2 x twisted pair with overall shield. • 50 to 75 pF/m capacitance core to core.

3.7 Alarm connection

An alarm buzzer can be connected using the power / data cable provided with the display.

Typical alarm connection

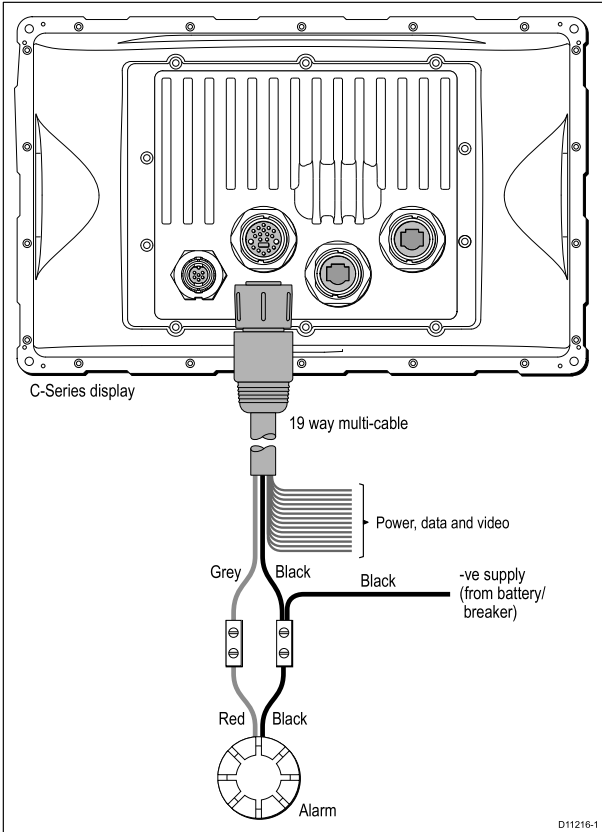

Note: The alarm output is rated for 100 mA maximum load

High alarm loads and third party alarms

You can use the alarm output to switch a relay. This may be useful for connecting high loads such as third party alarm sounders or inductive loads to the C-Series multifunction display. If you are in any doubt as to how to make such connections please consult an authorized installer.

The C-Series multifunction display has a positive switched alarm output. The following circuit shows the arrangement for connection of a relay switch.

Alarm output configured to switch a relay

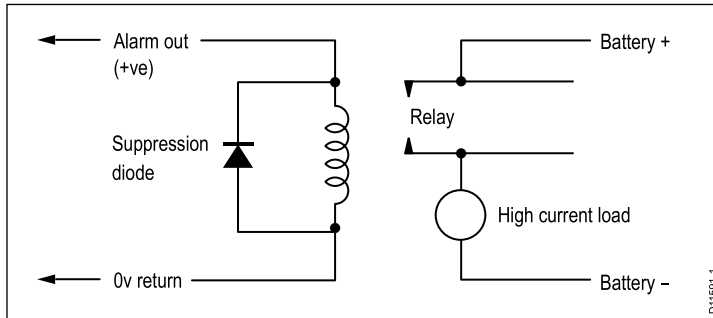

3.8 GPS connection

Depending upon your GPS type it may be either connected via SeaTalk or NMEA 0183.

See also

- For SeaTalk connection refer to: [3.6 SeaTalk connection](#).
- For NMEA 0183 connection refer to: [3.5 NMEA 0183 connection](#).

Note: When connecting the output to a relay or other inductive device you should fit a spike suppression diode e.g. 1N4001.

3.9 AIS connection

A compatible AIS can be connected using NMEA 0183.

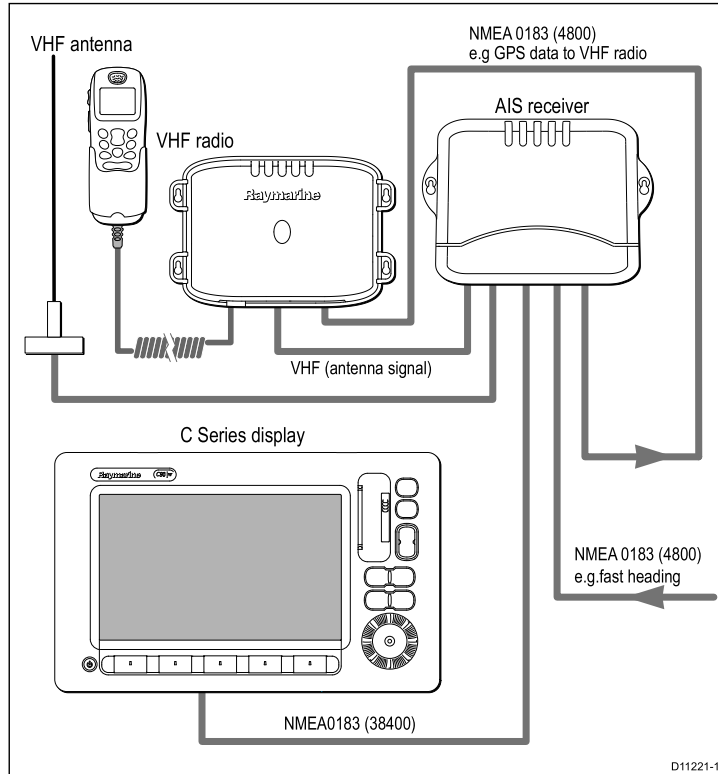

3.10 Fastheading connection

Fastheading data required for radar target acquisition (MARPA) may come from either the autopilot or a separate Raymarine Fastheading sensor.

Typical fastheading from NMEA 0183 compatible autopilot

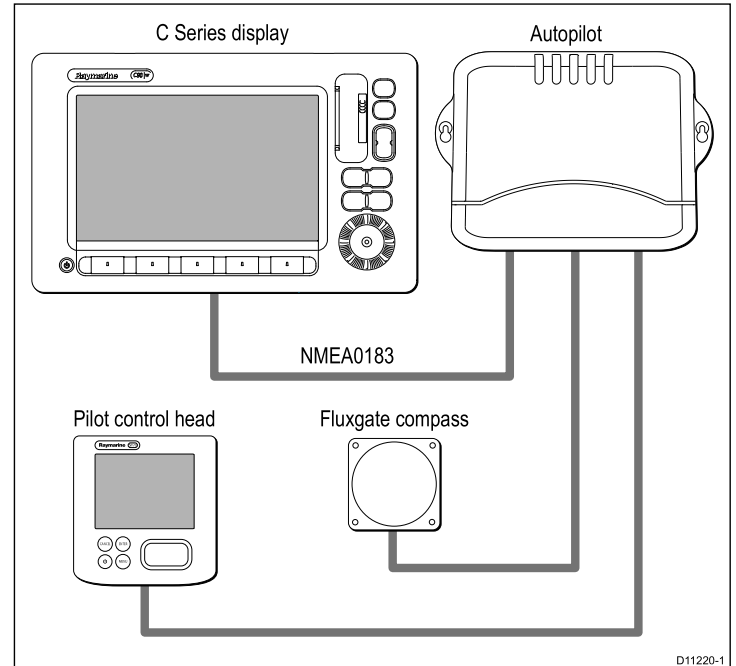

Note: The connection can be made into any NMEA 0183 port.

3.11 SeaTalk^{ng} connections

The C-Series Widescreen Display can connect as part of a SeaTalk^{ng} network.

The C-Series can use SeaTalk^{ng} to communicate with:

- SeaTalk^{ng} instruments (e.g. ST70)
- SeaTalk^{ng} autopilots (e.g. ST70 with SmartPilot SPX course computer)

Typical SeaTalk^{ng} system

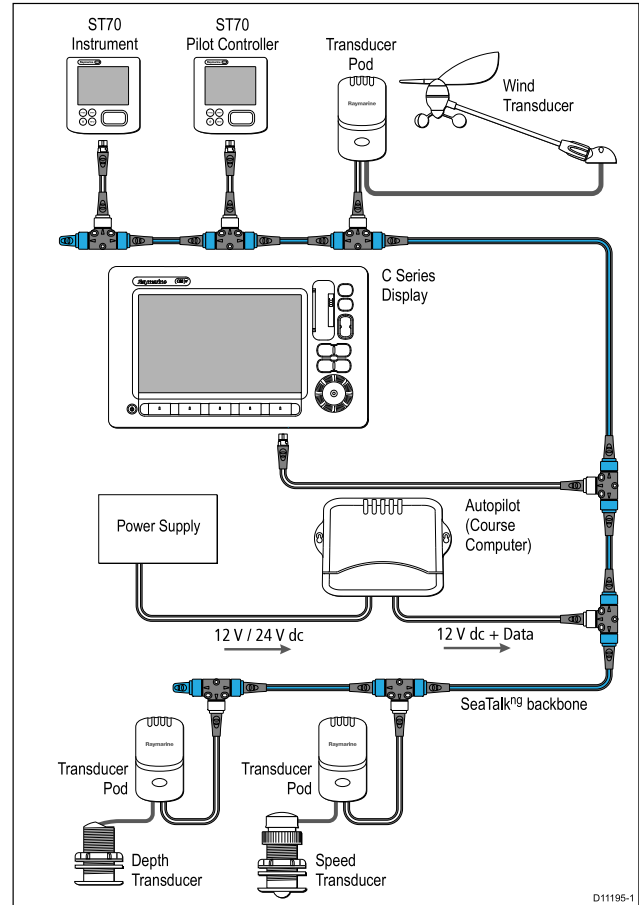

SeaTalk^{ng} cabling

SeaTalk^{ng} cables

Connection / Cable	Notes
Backbone cables (various lengths)	The main cable carrying data. Spurs from the backbone are used to connect SeaTalk ^{ng} devices.
T-piece connectors	Used to make junctions in the backbone to which devices can then be connected.
Terminators	Required at either end of the backbone.
Spur cables	Used to connect devices. Devices may be daisy chained or connected directly to the T-pieces.

Seataalk^{ng} power

The SeaTalk^{ng} bus requires a 12 V power supply. This may be provided from:

- Raymarine equipment with a regulated 12 V supply. (e.g. a SmartPilot SPX course computer)
- Other suitable 12 V supply.

Note: SeaTalk^{ng} does NOT supply power to multifunction displays and other equipment with a dedicated power supply input.

3.12 NMEA 2000 connection

NMEA 2000 devices are connected using the SeaTalk^{ng} bus. The display can receive data from NMEA 2000 devices (e.g. data from compatible engines). You may connect NMEA 2000 compatible devices using appropriate adaptor cables

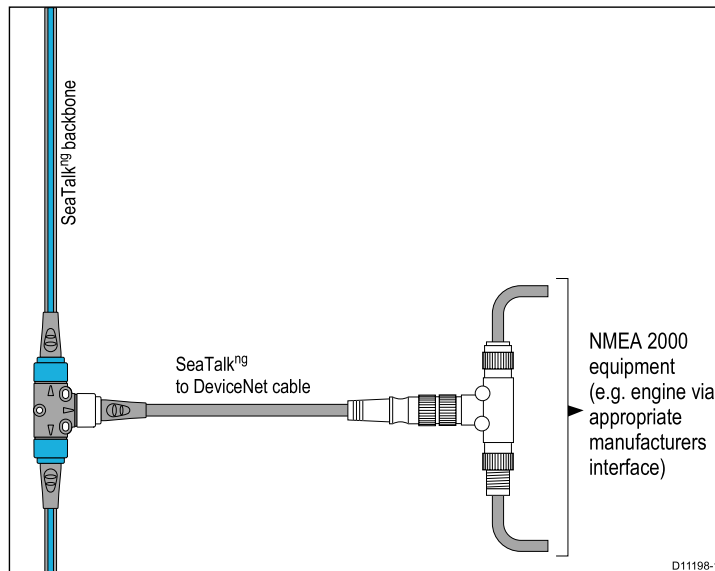

3.13 Video connection

The C-Series has an input for connection of cameras or other types of video equipment. The video connection is made using the combined power and data cable supplied with the unit. The connection is compatible with NTSC and PAL equipment.

Video connection

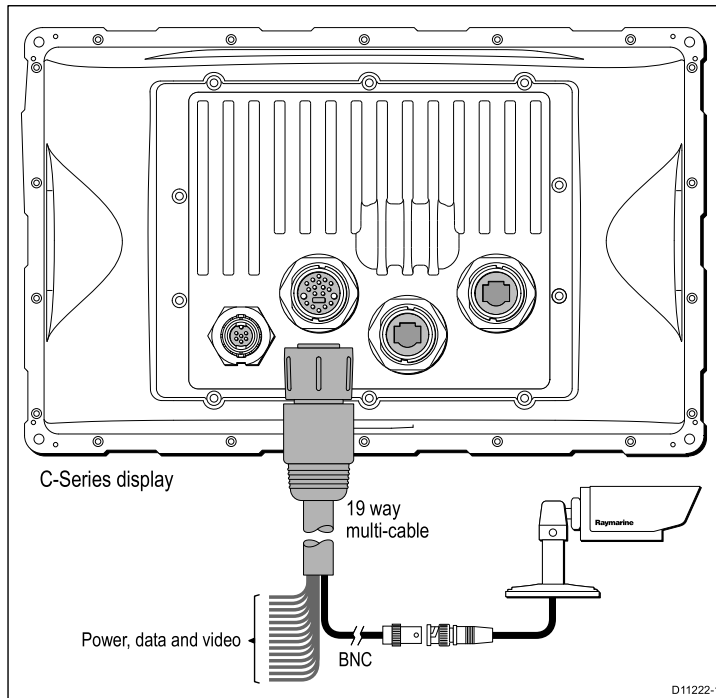

Chapter 4: Location and mounting

Chapter contents

- 4.1 Selecting a location on page 42
- 4.2 Flush mounting on page 45
- 4.3 Bracket (trunnion) mounting on page 46
- 4.4 Front bezel on page 48

4.1 Selecting a location



Warning: Potential ignition source

This product is NOT approved for use in hazardous/flammable atmospheres. Do NOT install in a hazardous/flammable atmosphere (such as in an engine room or near fuel tanks).

General location requirements

When selecting a location for your display it is important to consider a number of factors.

Key factors which can affect product performance are:

• **Ventilation**

To ensure adequate airflow:

- Ensure that equipment is mounted in a compartment of suitable size.
- Ensure that ventilation holes are not obstructed. Allow adequate separation of equipment.

Any specific requirements for each system component are provided later in this chapter.

• **Mounting surface.**

Ensure equipment is adequately supported on a secure surface. Do not mount units or cut holes in places which may damage the structure of the vessel.

• **Cable entry**

Ensure the unit is mounted in a location which allows proper routing and connection of cables:

- Minimum bend radius of 100 mm (3.94 in) unless otherwise stated.
- Use cable supports to prevent stress on connectors.

• **Water ingress**

The display is suitable for mounting both above and below decks. It is waterproof to IPX6 standard. Although the unit is waterproof, it is good practice to locate it in a protected area away from prolonged and direct exposure to rain and salt spray.

• **Viewing angle**

The contrast and colors seen on all LCD units varies slightly with viewing angle and are best viewed perpendicular to the display. Avoid locations where excessive reflection will occur in normal use

• **Electrical interference**

Select a location that is far enough away from devices that may cause interference, such as motors, generators and radio transmitters/receivers.

• **Magnetic compass**

Select a location that is at least 3 ft (1 m) away from a magnetic compass.

• **Power supply**

Select a location that is as close as possible to the boat's DC power source. This will help to keep cable runs to a minimum

C-Series Widescreen dimensions

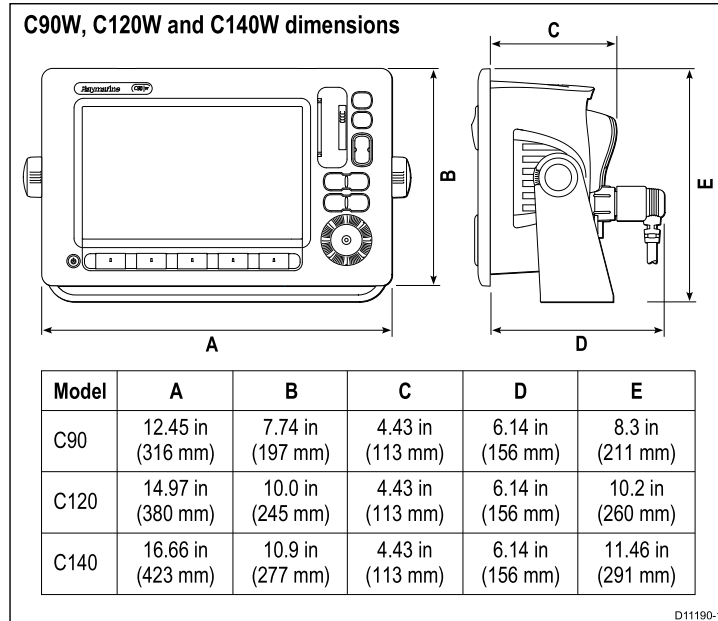

Mounting location

- **Above Decks mounting.**

Provides optimal GPS performance. (For equipment with appropriate waterproof rating.)

- **Below Decks mounting.**

Provides good performance with GRP construction vessels, however GPS may be less effective in poor prevailing conditions.

Note: Below decks mounting on vessels of non-GRP construction may require an external GPS mounted above decks.

Internal GPS environment

In addition to general guidelines concerning the location of marine electronics, there are a number of environmental factors to consider when installing equipment with an internal GPS antenna.

Typical locations and GPS performance

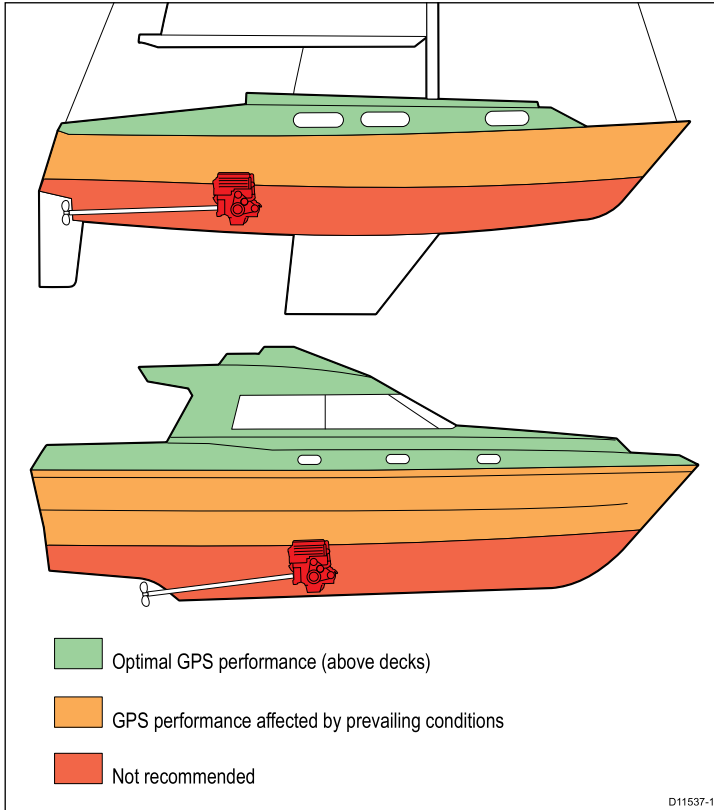

bulkhead, or the interior of larger vessels may result in a reduced GPS signal.

- **Other constructions.** GPS performance may be adversely affected below decks. Seek professional assistance and consider use of an external GPS antenna mounted above decks.

Prevailing conditions

The weather and location of the boat can affect the GPS performance. Typically calm clear conditions provide for a more accurate GPS fix. Vessels at extreme northerly or southerly latitudes may also receive a weaker GPS signal. GPS antenna mounted below decks will be more susceptible to performance issues related to the prevailing conditions.

Vessel construction

- **GRP vessels.** Unit can be mounted above and below decks. Although the proximity of heavy structure such as a structural

4.2 Flush mounting

The standard method for mounting a C-Series display is a flush or panel mounting arrangement.

Before mounting the unit, ensure that you have:

- Selected a suitable location
- Identified the cable connections and route that the cables will take
- Detached the front bezel

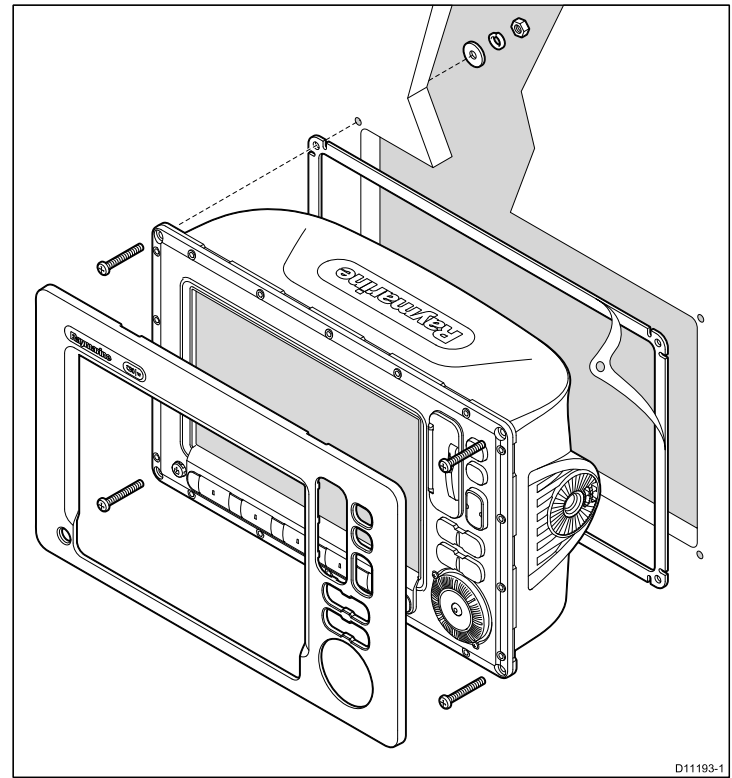

1. Check the selected location for the unit. A clear, flat area with suitable clearance behind the panel, is required.
2. Fix the appropriate cutting template supplied with the product, to the selected location, using masking or self-adhesive tape.
3. Using a suitable hole saw (the size is indicated on the template), make a pilot hole in each corner of the cut-out area.
4. Using a suitable saw, cut along the inside edge of the cut-out line.

5. Ensure that the unit fits into the removed area and then file around the cut edge until smooth.
 6. Drill four 4.5 mm (3/16 in) holes as indicated on the template to accept the securing bolts.
 7. Place the gasket onto the display unit and press firmly onto the flange.
 8. Connect the power, data and other cables to the unit.
 9. Slide the unit into place and secure using bolts provided.
- Once you have secured the display in place, proceed and attach the front bezel.

Fixing bolts

When flush mounting your display it is important to use bolts of an appropriate length. The length used is dependant upon the thickness of the mounting surface.

Thickness (mm)	Bolt length (mm)
<3	12
3-7	16
7-11	20
11-15	24
15-19	28
19-23	32

4.3 Bracket (trunnion) mounting

The C-Series widescreen display can be mounted on an optional bracket.

REQUIRES THE OPTIONAL MOUNTING BRACKET ACCESSORY.

Before mounting the unit ensure that you have:

- Selected a suitable location
- Identified the cable connections and route that the cables will take
- Attached the front bezel

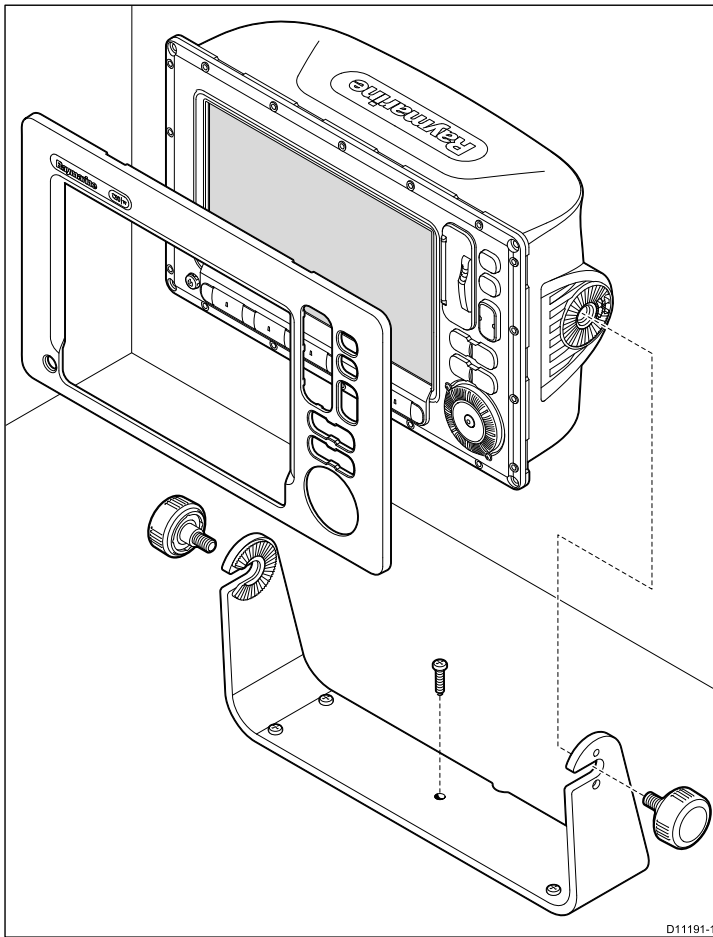

D11191-1

Note: Bracket (trunnion) mounting kit is available as an optional accessory.

1. Mark the location of the mounting bracket screw holes on the chosen mounting surface.
 2. Drill pilot holes for the screws using a suitable drill, taking care that there are no cables or anything that may be damaged behind the surface.
 3. Use the screws supplied to attach the mounting bracket securely.
 4. Fit the trim ring to the rear of the display using the M4 bolts supplied.
 5. Attach the display unit to the mounting bracket.
- Once you have secured the display in place, proceed and make the required cable connections.

4.4 Front bezel

Attaching the front bezel

Before fitting the bezel you must have mounted the unit in its required location.

1. Carefully lift one edge of the screen protection film, so that it is accessible for removing when unit installation is complete.
2. Place the bezel over the front of the C-Series Display, ensuring that locking lugs located at the bottom edge of the bezel are latched into position.

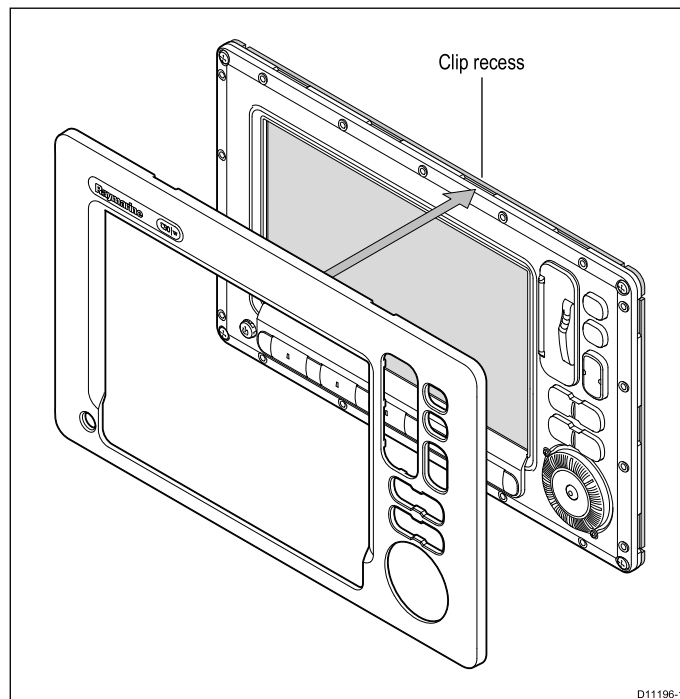

3. Ensure that the control buttons pass through their respective openings.
4. Apply firm but even pressure to the bezel along the:
 - i. Outer edges - work from the sides upwards and then along the top edge, to ensure that it clips securely into position.
 - ii. Inner edges - particularly along the chart card door edge, to ensure that the bezel sits flat.

5. Check that all control buttons are free to operate. It is suggested that you use your thumb or forefinger in a circular motion to do this.

Removing the front bezel

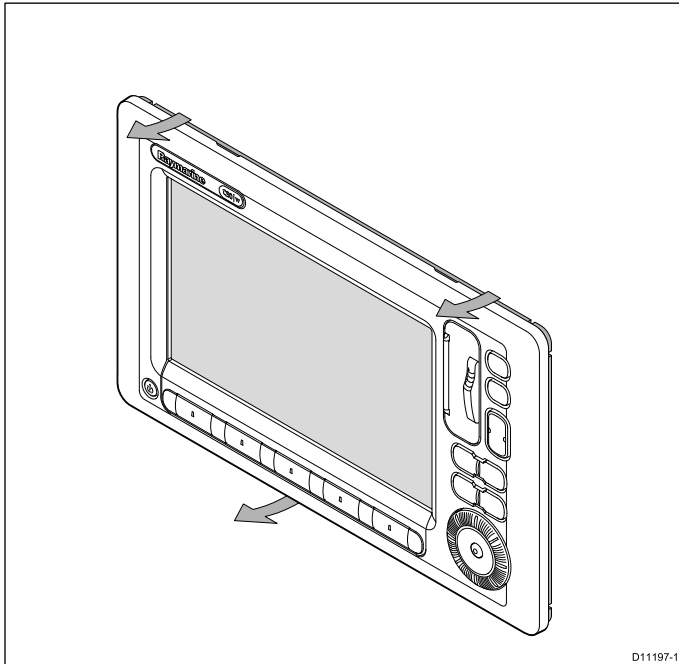

1. When removing the bezel, start at the bottom-middle and work around to the sides and top edge.

Chapter 5: System checks

Chapter contents

- [5.1 Initial power on test on page 52](#)
- [5.2 GPS check on page 53](#)
- [5.3 Radar check on page 54](#)
- [5.4 Sonar check on page 56](#)
- [5.5 Language selection on page 57](#)

5.1 Initial power on test

UniControl

The UniControl provides a number of key functions in a single control.

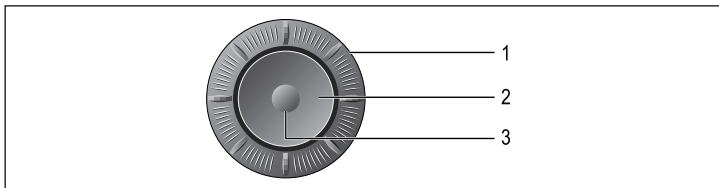

1. **Rotary Control.** Use this to select menu options and adjust the value of various items.
2. **Trackpad.** Use this to select menu items, options and move the cursor.
3. **OK button.** Use this to confirm a selection or entry.

Powering the display on

1. Press and hold the **POWER** button until the Raymarine logo appears.
2. Press **OK** to acknowledge the warning window.

Select a page set

When you first turn the display on you will be prompted to select a page set from those available.

Note: You can change the required page set at any time during normal operation.

Selecting a page set

To select a page set at first time power on:

1. Use the UniControl to select the required set of pages.

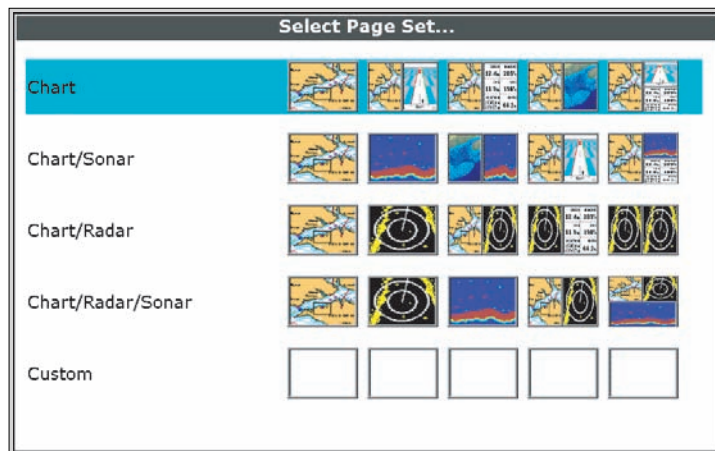

2. Press **OK**.

5.2 GPS check

Note: A solid circle on the chart indicates that neither heading nor Course Over Ground (COG) data is available.

Checking GPS operation

You can check that the GPS is functioning correctly using the chart application.

1. Press the **PAGE** button to show the available pages in the toolbar.
2. Press the **PAGE** button to switch between the available pages.
3. Press **OK** when the chart is displayed.

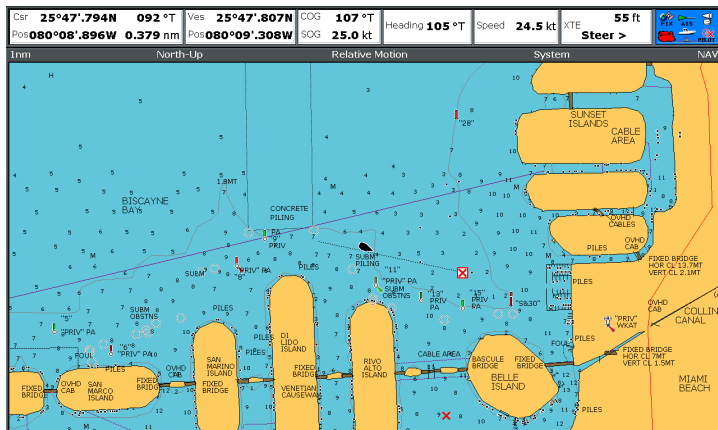

4. Check the screen.

With the chart displayed, you should see:

Your boat position (indicates a GPS fix). Your current position is represented by a boat symbol or solid circle. Your position is also displayed in the data bar under VES POS.

5.3 Radar check



Warning: Radar scanner safety

Before rotating the radar scanner, ensure all personnel are clear.



Warning: Radar transmission safety

The radar scanner transmits electromagnetic energy. Ensure all personnel are clear of the scanner when the radar is transmitting.

Checking the radar

1. Select a Radar page:
 - Press the **PAGE** button to select from the current page set.
 - Press and hold the **PAGE** button to select from all available pages.

The Radar scanners will now initialize in standby mode, this process will take approximately 70 seconds.

2. Press the **POWER** button.
3. Press the **Radar Tx/Stdby** softkey and set to Tx.

The scanners should now be transmitting and receiving.

4. Check that the radar screen is operating correctly.

Typical HD digital radar screen

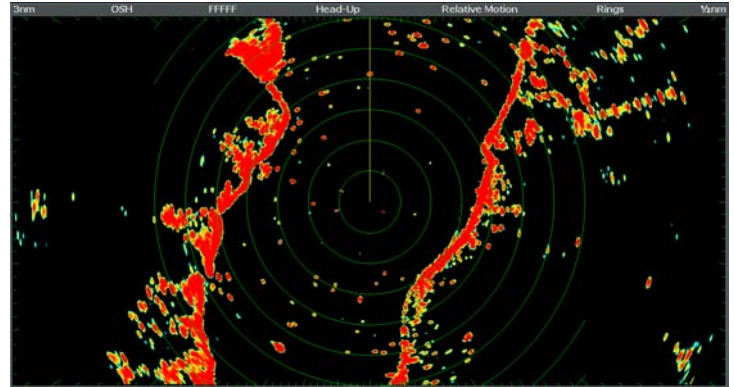

Note: Analog and non-HD radar screens will have different coloring / appearance.

Points to check:

- Radar sweep with echo responses are shown on screen.
- Radar status icon rotating in top right hand corner.

Check and adjust bearing alignment

Bearing alignment

The radar bearing alignment ensures that radar objects appear at the correct bearing relative to your boat's bow. You should check the bearing alignment for any new installation.

Example misaligned radar

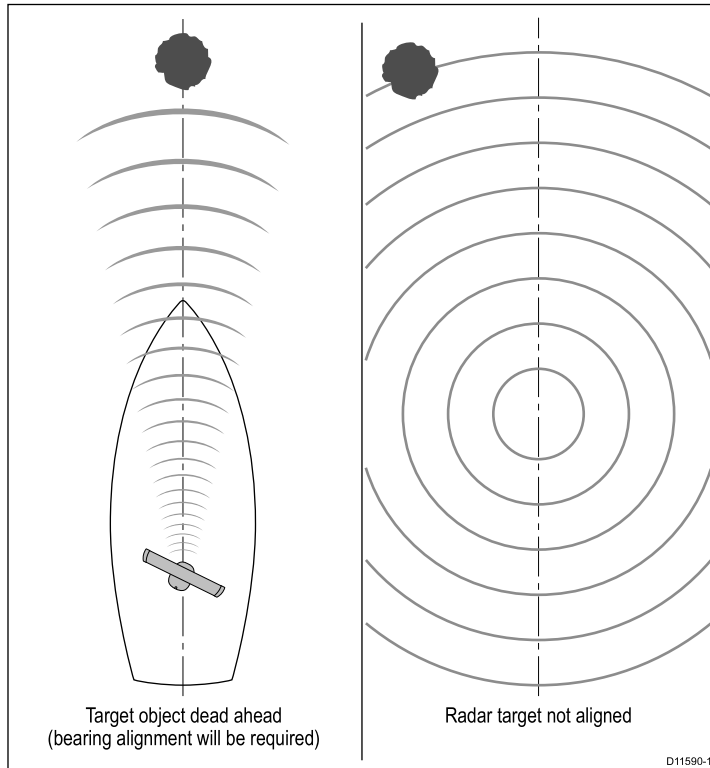

Checking the bearing alignment

1. With your vessel under way: Align the bow with a stationary object identified on the radar display. An object between 1 & 2 NM distant is ideal.

2. Note the position of the object on the radar display. If the target is not under the ship's heading marker (SHM), there is an alignment error and you will need to carry out bearing alignment adjustment.

Adjusting the bearing alignment

Once you have checked the bearing alignment you can proceed and make any required adjustments.

With the radar page displayed:

1. Select the bearing alignment menu.
2. Press the **BEARING ALIGNMENT** softkey.
3. Use the rotary control to place the selected target under the Ship's Heading Marker.
4. Press **OK** when complete.

Adjusting radar offset (parking)

This setting is applicable to open array scanners. It is used to ensure the scanner parks in the correct position when rotation stops.

Before you proceed, ensure that:

- The radar page is selected
 - The radar scanner is initialized standby mode
1. Press the **MENU** button and then select the radar setup menu (with the radar in standby mode).
 2. Select the **PARKING OFFSET** option, then adjust the offset angle required to park the radar so that the antenna comes to rest facing forward (you should see the Raymarine logo wording from the front of the vessel) when you place it in either standby or switch it off.
 3. Press **OK** when complete.

5.4 Sonar check



Warning: Sonar operation

- NEVER operate the sounder with the boat out of the water.
- NEVER touch the transducer face when the sounder is powered on.
- SWITCH OFF the sounder if divers are likely to be within 25 ft (5 m) of the transducer.

Select the fishfinder transducer

You must set up the system for the transducer connected to your DSM. Use the fishfinder setup menus to select the appropriate transducer.

Selecting the fishfinder transducer

From the main fishfinder screen:

1. Press the **MENU** button.
2. Select **Fishfinder Setup** from the list of options.
3. Select **Transducer Settings** from the list of menu options:
4. Use the **Select Transducer** option and select the appropriate transducer from those available.

Checking the sonar

Sonar checks are made using the fishfinder application.

1. Press the **PAGE** button to show the available pages in the toolbar.
2. Press the **PAGE** button to switch between the available pages.

3. Press **OK** when the fishfinder is displayed.

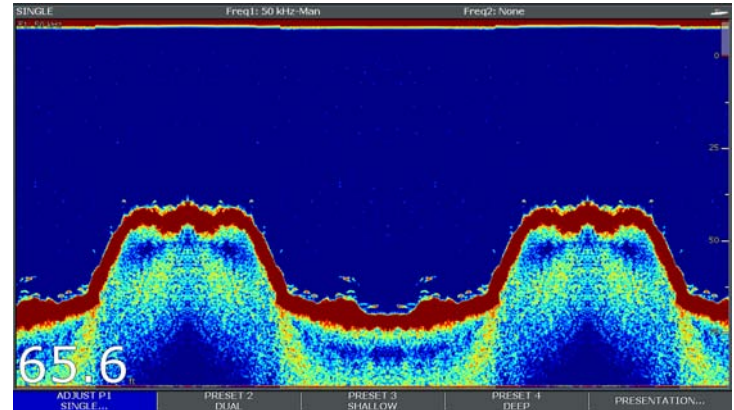

4. Check the fishfinder screen.

With the fishfinder active you should see:

- Depth reading (indicates the transducer is working). The depth is shown in large white numbers at the bottom left of the screen.

5.5 Language selection

The C-Series multifunction display can operate in the following languages:

English (US)	English (UK)	Chinese
Danish	Dutch	Finnish
French	German	Greek
Icelandic	Italian	Japanese
Korean	Norwegian	Portuguese
Russian	Spanish	Swedish

1. Press the **MENU** button to open the setup menu.
2. Use the trackpad up / down to select the **System Setup** menu.
3. Use the trackpad right to open the sub-menu.
4. Use the trackpad to select the **Language** options.
5. Select from the languages available.
6. Press **OK** to accept and save the change.
7. Press **OK** again to return back through the menus to the normal display.

Chapter 6: Troubleshooting

Chapter contents

- [6.1 Troubleshooting on page 60](#)
- [6.2 Power up troubleshooting on page 60](#)
- [6.3 Radar troubleshooting on page 61](#)
- [6.4 GPS troubleshooting on page 62](#)
- [6.5 Sonar troubleshooting on page 63](#)
- [6.6 System data troubleshooting on page 64](#)
- [6.7 SeaTalk^{hs} LED indications on page 65](#)
- [6.8 Miscellaneous troubleshooting on page 66](#)

6.1 Troubleshooting

The troubleshooting information provides possible causes and corrective action required for common problems associated with marine electronics installations.

All Raymarine products are, prior to packing and shipping, subjected to comprehensive test and quality assurance programs. However, if you experience problems with the operation of your C-Series multifunction display, this section will help you to diagnose and correct problems in order to restore normal operation.

If after referring to this section you are still having problems with your unit, please contact Raymarine Technical Support for further advice.

6.2 Power up troubleshooting

Problems at power up and their possible causes and solutions are described here.

Problem	Possible causes	Possible solutions
The display does not start up.	Problem with power to the unit.	Check relevant fuses and breakers.
		Check that the power supply cable is sound and that all connections are tight and free from corrosion.
		Check that the power source is of the correct voltage and sufficient current.

6.3 Radar troubleshooting

Problems with the radar and their possible causes and solutions are described here.

Problem	Possible causes	Possible solutions
No Data or No scanner message.	Radar scanner power supply.	Check that the scanner power supply cable is sound and that all connections are tight and free from corrosion.
		Check relevant fuses and breakers.
		Check power source is of the correct voltage and sufficient current (using voltage booster if appropriate).
	SeaTalk ^{hs} network problem.	Check that the Scanner is correctly connected to the display via a cross over coupler or SeaTalk ^{hs} switch.
		Check the status of the SeaTalk ^{hs} Switch.
		Check that SeaTalk ^{hs} cables are free from damage.
	Software mismatch between equipment may prevent communication.	Contact Raymarine technical support.
	Switch at scanner pedestal in OFF position.	Ensure scanner pedestal switch is in ON position.

Problem	Possible causes	Possible solutions
The bearing of a target on the radar screen is incorrect.	The radar bearing alignment requires correcting.	Check and adjust radar bearing alignment.

6.4 GPS troubleshooting

Problems with the GPS and their possible causes and solutions are described here.

Problem	Possible causes	Possible solutions
"No Fix" GPS status icon is displayed.	Geographic location or prevailing conditions preventing satellite fix.	Check periodically to see if a fix is obtained in better conditions or another geographic location.
	External GPS antenna conflict with internal GPS.	Disable internal GPS from within the setup menus.
	Internal GPS antenna has been disabled.	Enable internal GPS from within the setup menus.
	External GPS connection fault.	Ensure that GPS connections and cabling are correct and fault free..
	Unit mounted in poor location. For example: <ul style="list-style-type: none"> • Below decks on Steel construction vessel. • Close proximity to transmitting equipment such as VHF radio. 	Ensure that the unit is mounted in accordance with the instructions.
	External GPS antenna in	Ensure GPS antenna

	poor position.	has a clear view of the sky.
	GPS installation problem.	Refer to manufacturers handbook for installation details.

6.5 Sonar troubleshooting

Problems with the sonar and their possible causes and solutions are described here.

Note: A GPS Status screen is available within the Setup menu. This provides satellite signal strength and other relevant information.

Problem	Possible causes	Possible solutions
No data source for the fishfinder.	DSM power supply fault.	Check the DSM power supply and cables.
	Other DSM fault.	Refer to the instructions supplied with the DSM unit.
	SeaTalk ^{hs} network problem.	Check that the DSM is correctly connected to the display or SeaTalk ^{hs} switch.
		Check the status of the SeaTalk ^{hs} Switch.
		Check that SeaTalk ^{hs} cables are free from damage.
Software mismatch between equipment may prevent communication.	Contact Raymarine technical support.	

Problem	Possible causes	Possible solutions
Problematic depth readings or sonar image.	Gain or Frequency settings may be inappropriate for present conditions.	Check the fishfinder presets, gain and frequency settings.
	DSM cable fault.	Ensure that the power, transducer and all other cables to the DSM unit are properly connected and free from damage.
	Other DSM fault.	Refer to the instructions supplied with the DSM unit.

6.6 System data troubleshooting

Aspects of the installation can cause problems with the data shared between connected equipment. Such problems, their possible causes and solutions are described here.

Problem	Possible causes	Possible solutions
Instrument, engine or other system data is unavailable at all displays.	Data is not being received at the display.	Check the data bus (e.g. SeaTalk ^{ng}) wiring and connection to the display.
		Check the overall integrity of the data bus (e.g. SeaTalk ^{ng}) wiring.
		If available refer to the reference guide for the data bus. (e.g. SeaTalk ^{ng} reference manual)
	Data source (e.g. ST70 instrument or engine interface) is not operating.	Check the source of the missing data (e.g. ST70 instrument or engine interface).
		Check the power to the SeaTalk bus.
		Refer to the manufacturer's handbook for the equipment in question.
Software mismatch between equipment may prevent communication.	Contact Raymarine technical support.	

Instrument or other system data is missing from some but not all displays.	SeaTalk ^{hs} network problem	Check that all required equipment is connected to the SeaTalk ^{hs} switch.
		Check the status of the SeaTalk ^{hs} Switch.
		Check that SeaTalk ^{hs} cables are free from damage.
	Software mismatch between equipment may prevent communication.	Contact Raymarine technical support

6.7 SeaTalk^{hs} LED indications

LED indications associated with the SeaTalk^{hs} switch are described here.

LED state	Possible causes
For all connected channels: 1 steady and 1 flashing green LED.	No problem detected (Steady LED indicates network connection Flashing LED indicates network traffic) .
No LEDs are illuminated.	No power to the SeaTalk ^{hs} switch.
Some LEDs are not illuminated.	<ul style="list-style-type: none"> • Cable / connection faults on the channels with non-illuminated LEDs. • Equipment connected to non-illuminated LEDs may be faulty.

6.8 Miscellaneous troubleshooting

Miscellaneous problems and their possible causes and solutions are described here.

Problem	Possible causes	Possible solutions
Display behaves erratically: <ul style="list-style-type: none"> • Frequent unexpected resets. • System crashes or other erratic behavior. 	Intermittent problem with power to the display.	Check relevant fuses and breakers.
		Check that the power supply cable is sound and that all connections are tight and free from corrosion.
		Check that the power source is of the correct voltage and sufficient current.
	Buttons trapped by front bezel.	Ensure that the front bezel is fitted correctly and that all buttons are free to operate correctly.
	Software mismatch on system (upgrade required).	Go to www.raymarine.com and click on support for the latest software downloads.
Corrupt data / other unknown issue.	Perform a factory reset. This option can be found within Menu > System Setup > Settings and Data Reset .	

Problem	Possible causes	Possible solutions
		<div style="border: 1px solid black; padding: 5px;"> <p>Important: This will result in the loss of any settings and data (such as waypoints) stored on the display. Please save any important data to a CF card before resetting.</p> </div>

Chapter 7: Technical support

Chapter contents

- 7.1 Raymarine technical support on page 70
- 7.2 Sirius support on page 70
- 7.3 Navionics support on page 71

7.1 Raymarine technical support

Web support

Please visit the customer support area of our website at:

www.raymarine.com

This contains Frequently Asked Questions, servicing information, e-mail access to the Raymarine Technical Support Department and details of worldwide Raymarine agents.

Telephone support

In the USA call:

+1 603 881 5200 extension 2444

In the UK, Europe, the Middle East, or Far East call:

+44 (0)23 9271 4713

Product information

If you need to request service, please have the following information to hand:

- Product name.
- Product identity.
- Serial number.
- Software application version.

You can obtain this product information using the menus within your product.

Viewing product information

1. Open the system Setup menu.
2. Select System Diagnostics.
3. Select Software Services.
4. Select the Software Services menu:

7.2 Sirius support

Sirius marine weather

www.sirius.com/marineweather

Sirius audio

www.sirius.com

7.3 Navionics support

Navionics website

www.navionics.com

Chapter 8: Technical specification

Chapter contents

- [8.1 Technical specification on page 74](#)

8.1 Technical specification

Nominal supply voltage	12 or 24 V dc
Operating voltage range	10.7 to 32 V dc
Fuse / Breakers	In-line fuse (fitted within power cable) <ul style="list-style-type: none"> • 7 A. (Standard 20 mm glass fuse)
Current	4 A max operating current
Power consumption	32 W typical power consumption
Environmental	<p>Installation environment</p> <ul style="list-style-type: none"> • Operating temperature: -10 °C to 50 ° (14 °F to 122 °F) • Non-operating temperature: -20 °C to 70 °C (-4 °F to 158 °F) • Relative humidity: max 95% • Water proof to IPX6 <p>Storage conditions (when packed):</p> <ul style="list-style-type: none"> • Temperature: -25 °C to 55 °C (-13 °F to 158 °F) • Relative humidity: max 75%

Weight	<ul style="list-style-type: none"> • C90W: 3.8 kg (8.5 lb) • C120W: 4.8 kg (10.5 lb) • C140W: 5.6 kg (12.3 lb)
Display screen	<p>TFT LCD display, 24bit color (16.7 M colors)</p> <ul style="list-style-type: none"> • C90W: 9 in display, 800 x 480 pixels • C120W: 12 in display, 1280 x 800 pixels • C140W: 14 in display, 1280 x 800 pixels
Data connections.	<p>3 x NMEA 0183 ports:</p> <ul style="list-style-type: none"> • NMEA port 1: I/O 4800/9600 baud. • NMEA port 2: I/O 4800/9600/38400 baud. • NMEA port 3: Input only, 4800 baud. <p>1 x SeaTalk port. 2 x SeaTalk^{HS} RJ45 type connections</p> <ul style="list-style-type: none"> • 10/100 Mb/s <p>1 x SeaTalk^{NG} connection</p>

GPS	<ul style="list-style-type: none"> • 12 channel receiver • Sirf star chipset for high sensitivity and rapid fix • Frequency of operation: 1575.43 Mhz +/- 1Mhz (C/A code), L1 • Sensitivity: -159dBm (tracking), -142dBm acquisition • Signal Acquisition: Automatic • Cold Start 35 seconds to 2.5 minutes under good signal conditions • SBAS: WAAS/EGNOS compatible • Almanac update: Automatic • Horizontal Positional Accuracy: <=15 metre @ 95% of time (without SA), <=5metres @ 95% with WAAS/EGNOS • Geodetic Datum: WGS-84 (alternatives available through Raymarine display) • Update rate: Once a second • Helical antenna for even antenna gain across most display orientations • GPS data bridged to NMEA 0183, SeaTalk and SeaTalk^{ng} outputs.
-----	---

Cartography	Navionics embedded cartography appropriate to purchase region. (North America, Europe or Rest of World, as appropriate)
Conformance	<ul style="list-style-type: none"> • Europe: R&TTE 1999/5/EC • Australia and New Zealand: C-Tick, Compliance Level 2 

Chapter 9: Options and accessories

Chapter contents

- 9.1 SeaTalk accessories on page 78
- 9.2 SeaTalk^{ng} accessories on page 78
- 9.3 SeaTalk^{hs} accessories on page 79
- 9.4 Spares and accessories on page 81

9.1 SeaTalk accessories

SeaTalk cables and accessories for use with compatible products.

Description	Part No	Notes
NMEA / SeaTalk converter	E85001	
3 m (9.8 ft) SeaTalk extension cable	D285	
5 m (16.4 ft) SeaTalk extension cable	D286	
9 m (29.5 ft) SeaTalk extension cable	D287	
12 m (39.4 ft) SeaTalk extension cable	E25051	
20 m (65.6 ft) SeaTalk extension cable	D288	

9.2 SeaTalk^{ng} accessories

SeaTalk^{ng} cables and accessories for use with compatible products.

Description	Part No	Notes
Backbone Kit	A25062	Includes: <ul style="list-style-type: none"> • 2 x 5 m (16.4 ft) Backbone cable • 1 x 20 m (65.6 ft) Backbone cable • 4 x T-piece • 2 x Backbone terminator • 1 x Power cable
SeaTalk ^{ng} 0.4 m (1.3 ft) spur	A06038	
SeaTalk ^{ng} 1 m (3.3 ft) spur	A06039	
SeaTalk ^{ng} 3 m (9.8 ft) spur	A06040	
SeaTalk ^{ng} 5 m (16.4 ft) spur	A06041	
SeaTalk ^{ng} 0.4 m (1.3 ft) backbone	A06033	
SeaTalk ^{ng} 1 m (3.3 ft) backbone	A06034	

Description	Part No	Notes
SeaTalk ^{ng} 3 m (9.8 ft) backbone	A06035	
SeaTalk ^{ng} 5 m (16.4 ft) backbone	A06036	
SeaTalk ^{ng} 20 m (65.6 ft) backbone	A06037	
SeaTalk ^{ng} - bare ends 1 m (3.3 ft) spur	A06043	
SeaTalk ^{ng} - bare ends 3 m (9.8 ft) spur	A06044	
SeaTalk ^{ng} — SeaTalk2 0.4 m (1.3 ft) spur	A06048	
SeaTalk ^{ng} Power cable	A06049	
SeaTalk ^{ng} Terminator	A06031	
SeaTalk ^{ng} T-Piece	A06028	
SeaTalk ^{ng} E-Piece	A06064	
SeaTalk ^{ng} Blanking plug	A06032	

9.3 SeaTalk^{hs} accessories

Digital radar scanner cables

Scanner cables

Connect the Radar scanner to either the SeaTalk^{hs} switch or the cross over coupler.

Cable	Part number	Notes
5 m (16.4 ft) Digital cable	A55076	
10 m (32.8 ft) Digital cable	A55077	Your radar scanner may include the 10 m cable (depending upon the model purchased)
15 m (49.2 ft) Digital cable	A55078	
25 m (82.0 ft) Digital cable	A55079	

Scanner extension cables

Use of one of these cables to extend the connection between the radar scanner and the SeaTalk^{hs} switch or cross over coupler.

Cable	Part number	Notes
2.5 m (8.2 ft) extension cable	A92141	
5 m (16.4 ft) extension cable	A55080	
10 m (32.8 ft) extension cable	A55081	

SeaTalk^{hs} network cables

SeaTalk^{hs} network cables

Standard network cables connect compatible equipment to the SeaTalk^{hs} switch (or cross over coupler), they have a waterproof connector at one end.

Cable	Part number	Notes
1.5 m (4.9 ft) SeaTalk ^{hs} network cable	E55049	
5 m (16.4 ft) SeaTalk ^{hs} network cable	E55050	
10 m (32.8 ft) SeaTalk ^{hs} network cable	E55051	
20 m (65.6 ft) SeaTalk ^{hs} network cable	E55052	

Fully waterproof SeaTalk^{hs} network cables

Connect directly from display to display.

Cable	Part number	Notes
1.5 m (4.9 ft) Dual end SeaTalk ^{hs} network cable.	A62245	Cable has waterproof connectors at both ends.
15 m (49.2 ft) Dual end SeaTalk ^{hs} network cable	A62246	Cable has waterproof connectors at both ends.

SeaTalk^{hs} hardware

Cable	Part number	Notes
SeaTalk ^{hs} switch	E55058	8 way hub for network connection of multiple SeaTalk ^{hs} devices.
SeaTalk ^{hs} coupler	E55060	Couple for connection of a single SeaTalk ^{hs} device.

9.4 Spares and accessories

Options and accessories for the C-Series Widescreen Multifunction displays.

Optional accessories

Description	Part No	Notes
Trunnion (bracket) mount kit (C190W)	A62132	
Trunnion (bracket) mount kit (C120W)	A62133	
Trunnion (bracket) mount kit (C140W)	A62134	

Spare / replacement parts

Description	Part No	Notes
Flush mount kit (C90W)	R62125	
Flush mount kit (C120W)	R62126	
Flush mount kit (C140W)	R62127	
Trunnion knob	R08001	
Suncover (C90W)	R62122	
Suncover (C120W)	R62123	
Suncover (C140W)	R62124	

Description	Part No	Notes
1.5 m (4.9 ft) Power and data cable — straight	R62131	
1.5 m (4.9 ft) Power and data cable — 90 degree	R62227	
SeaTalk ^{hs} dust cap	R62228	
SeaTalk ^{ng} dust cap	R62229	

Service spares

Description	Part No	Notes
Chart door	R62184	
Rotary Trackpad	R62185	
Seal Set (C90W)	R62186	
Seal Set (C120W)	R62187	
Seal Set (C140W)	R62188	
Keymat set	R62189	
Keycap set	R62190	
Front panel (C90W)	R62191	
Front panel (C120W)	R62192	
Front panel (C140W)	R62193	
Bonded LCD Assembly (C90W)	R62199	

Description	Part No	Notes
Bonded LCD Assembly (C120W)	R62200	
Bonded LCD Assembly (C140W)	R62206	
Chartreader assembly	R62209	
Chartreader cable assembly	R62210	
Lower keyboard assy (C90W)	R62211	
Lower keyboard assy (C120W)	R62212	
Lower keyboard assy (C140W)	R62213	
Side keyboard assy	R62214	
Rotary keyboard assy	R62215	
Keyboard cable assy	R62216	
GPS assembly (C90W)	R62217	
GPS assembly (C120W)	R62218	
GPS assembly (C140W)	R62218	
GPS cable assy	R62219	
LVDS cable assy	R62221	
CCFL cable assy (C140W Only)	R62220	

Description	Part No	Notes
I/O PCB assy	R62222	
CPU pcb assy	R62223	
CPU-IO cable assy	R62224	
EMC pad	R62225	
Heat pad set	R62226	

Appendix A Connectors and pinouts

Power, data and video connector

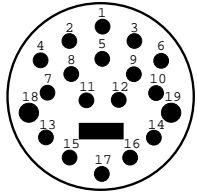

Item	Remarks
Identification	PWR/NMEA/ST/Video
Connector type	19 pin twist-lock
Current source to network	No current sourced for external devices.
Current sink from network	<ul style="list-style-type: none"> • PSU: Main Power input. • NMEA: No power required for interface. • ST1: <50mA (Interface drive only). • Video: No power required for interface.

Power, data and video cable cores and colors

Signal	Pin	Cable	AWG	Grouping	Color
BATT+	18	32/0.2	18		Red
BATT-	19	32/0.2	18		Black

Signal	Pin	Cable	AWG	Grouping	Color
SCREEN	17	not used			
NMEA1 TX+	6	7/0.15	26	Twisted pair	Yellow
NMEA1 TX-	9	7/0.15	26		Brown
NMEA1 RX+	4	7/0.15	26	Twisted pair	White
NMEA1 RX-	8	7/0.15	26		Green
NMEA2 TX+	1	7/0.15	26	Twisted pair	Orange / Yellow
NMEA2 TX-	3	7/0.15	26		Orange / Brown
NMEA2 RX+	7	7/0.15	26	Twisted pair	Orange / White
NMEA2 RX-	11	7/0.15	26		Orange / Green
NMEA3 RX+	5	7/0.15	26	Twisted pair	Blue / White
NMEA3 RX-	2	7/0.15	26		Blue / Green
ST1 BATT+	10	7/0.15	26		White / Red
ST1 DATA	12	7/0.15	26		White / Yellow

Signal	Pin	Cable	AWG	Grouping	Color
HONK	16	7/0.15	26		Grey
ST1 BATT-	14	7/0.15	26		White / Black
VIDEO	15	RG179 75R coax (or equivalent)			
VIDEO RTN	13	Screen			

SeaTalk^{ng} connector

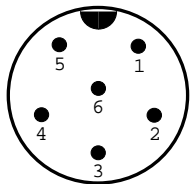

Item	Remarks
Identification	ST2/NMEA2000
Connector type	STNG
Current source to network	No current sourced for external devices
Current sink from network	<160mA (Interface drive only)

Pin	Signal
1	+12V
2	0V
3	Screen
4	CanH
5	CanL
6	SeaTalk (not connected)

Note: Use only Raymarine cables when connecting to SeaTalk^{ng}

SeaTalk^{hs} connector

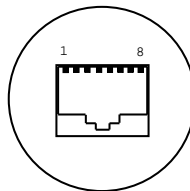

Item	Remarks
Identification	STHS
Connector type	RJ45 (with suitable waterproofing)
Current source to network	No current sourced for external devices
Current sink from network	No power required for interface

Pin	Signal
1	Tx+
2	Tx-
3	Rx+
4	Not connected
5	Not connected
6	Rx-
7	Not connected
8	Not connected

Note: Use only Raymarine cables when connecting to SeaTalk^{hs}

Appendix B NMEA 0183 sentences

The C-Series Widescreen display supports the following NMEA 0183 sentences. These are applicable to NMEA 0183 and SeaTalk protocols.

Transmit

APB	Autopilot b
BWC	Bearing and distance to waypoint
BWR	Bearing and distance to waypoint rhumb line
DBT	Depth below transducer
DPT	Depth
MTW	Water temperature
RMB	Recommended minimum navigation information
RSD	Radar system data
TTM	Tracked target message
VHW	Water speed and heading
VLW	Distance travelled through the water
GGA	Global positioning system fix data
GLL	Geographic position latitude longitude
GSA	GPS DOP and active satellites
GSV	GPS satellites in view
RMA	Recommended minimum specific loran c data

RMC	Recommended minimum specific GPS transit data
VTG	Course over ground and ground speed
ZDA	Time and date
MWV	Wind speed and angle
RTE	Routes sentence
WPL	Waypoint location sentence

Receive

AAM	Waypoint arrival alarm sentence
DBT	Depth below transducer sentence
DPT	Depth sentence
DTM	Datum reference sentence
APB	Autopilot b sentence
BWC	Bearing and distance to waypoint sentence
BWR	Bearing and distance to waypoint rhumb line sentence
DSC	Digital selective calling information sentence
DSE	Distress sentence expansion
GGA	Global positioning system fix data sentence

	Geographic position loran c sentence GLC
GLL	Geographic position latitude longitude sentence
GSA	GPS DOP and active satellites sentence
GSV	GPS satellites in view sentence
HDG	Heading deviation and variation sentence
HDT	Heading true sentence
HDM	Heading magnetic sentence
MSK	MSK receiver interface sentence
MSS	MSK receive r signal status sentence
MTW	Water temperature sentence
WMV	Wind speed and angle sentence
RMA	Recommended minimum specific loran c data sentence
RMB	Recommended minimum navigation information sentence
RMC	Recommended minimum specific GPS transit data sentence
VHW	Water speed and heading sentence
VLW	Distance travelled through the water sentence
VTG	Course over ground and ground speed sentence

XTE	Cross track error measured sentence
ZDA	Time and date sentence
MDA	Meteorological composite sentence
GBS	GPS satellite fault detection data sentence
RTE	Routes sentence
WPL	Waypoint location sentence

Appendix C NMEA 2000 sentences

The C-Series Widescreen display supports the following NMEA 2000 sentences. These are applicable to NMEA 2000, SeaTalk^{ng} and SeaTalk 2 protocols.

Transmit

128267	Water depth
129283	Cross track error
129291	Set and drift rapid update
129301	Time to mark
130578	Vessel speed components
129026	COG SOG rapid update
130577	Direction data
129550	GNSS differential correction receiver interface
129551	GNSS differential correction receiver signal
129029	GNSS position data
129540	GNSS sats in view
129284	Navigation data
129025	Position rapid update
128275	Distance log
128259	Speed
127237	Heading track control

127245	Rudder
127250	Vessel heading
126992	System time
129033	Time and date
130310	Environmental parameters
130306	Wind data
129044	Datum
126464	Pgn list
126996	Product information

Receive

129026	NMEA 2000 COG and SOG rapid update message
129283	NMEA 2000 cross track error message
129044	NMEA 2000 datum message
130577	NMEA 2000 direction data message
128275	NMEA 2000 distance log message
130310	NMEA 2000 environmental parameters message
130311	NMEA 2000 environmental parameters message
129550	NMEA 2000 GNSS differential correction receiver interface message
129551	NMEA 2000 GNSS differential correction receiver signal message

129539	NMEA 2000 GNSS DOPs message
129029	GNSS position data
129545	NMEA 2000 GNSS RAIM output message
129540	GNSS Sats in view
127237	Heading / track control
129284	Navigation data
129025	Position rapid update
127245	Rudder
129291	Set and drift rapid update
128259	Speed
126992	System time
129033	Time and date
129301	Time to or from mark
127250	Vessel heading
130578	Vessel speed components
128267	Water depth
130306	Wind data
130576	Small craft status
127489	Dynamic engine parameters
127488	Engine parameters rapid update
127493	Dynamic transmission

127505	Fluid level
127498	Static engine parameters
126464	PGN List
126996	Product information

Raymarine plc

Anchorage Park, Portsmouth,
Hampshire PO3 5TD,
United Kingdom.

Tel: +44 (0) 23 9269 3611
Fax: +44 (0) 23 9269 4642

www.raymarine.com

Raymarine Inc.

21 Manchester Street, Merrimack,
New Hampshire 03054-4801,
USA.

Tel: +1 603.881.5200
Fax: +1 603.864.4756

www.raymarine.com

Raymarine®
...world leaders in marine electronics.

